



TWIN ROTARY ASSEMBLIES

JD 72-7520
CAB, WOC

Current as of 04/21/05



PARTS LISTING WITH MOUNTING AND OPERATING INSTRUCTIONS

Tiger Corporation
3301 N. Louise Ave.
Sioux Falls, SD 57107
1-800-843-6849
1-605-336-7900

06012001

TO THE OWNER / OPERATOR / DEALER

All implements with moving parts are potentially hazardous. There is no substitute for a cautious, safe-minded operator who recognizes the potential hazards and follows reasonable safety practices. The manufacturer has designed this implement to be used with all its safety equipment properly attached to minimize the chance of accidents.

BEFORE YOU START!! Read the safety messages on the implement and shown in this manual. Observe the rules of safety and use common sense!

READ AND UNDERSTAND THIS MANUAL! Non-English speaking operators will need to GET THE MANUAL TRANSLATED as needed!



DANGER

FAILING TO FOLLOW SAFETY MESSAGES AND OPERATING INSTRUCTIONS CAN CAUSE SERIOUS BODILY INJURY OR EVEN DEATH TO OPERATOR AND OTHERS IN THE AREA.



1. Study and understand Operator's Manuals, Safety Decals, and Instructional Decals for tractor and implement to prevent misuse, abuse, and accidents. Practice before operating in a confined area or near passersby.

● Learn how to stop engine suddenly in an emergency. Be alert for passersby and especially children

2. Allow no children on or near folding mower or tractor. Allow no riders on tractor or implement. Falling off may cause serious injury or death from being run over by tractor or mower or contact with rotating blades.

3. Operate only with tractor having Roll-Over Protective Structure (ROPS) and with seat belt securely fastened to prevent injury and possible death from falling off or tractor overturn.

● Personal Protective Equipment such as Hard Hat, Safety Glasses, Safety Shoes, & Ear Plugs are recommended.

4. Block up or support raised machine and all lifted components securely before putting hands or feet under or working underneath any lifted component to prevent crushing injury or death from sudden dropping or inadvertent operation of controls. Make certain area is clear before lowering or folding

5. Before transporting, put Lift Lever in detent or full-lift position. Install Transport Safety Devices securely on folding mowers. Put Booms securely in Transport Rest.

● Folding and Boom Mowers have raised center of gravity. Slow down when turning and on hillsides.

6. Make certain that SMV sign, warning lights, and reflectors are clearly visible. Follow local traffic codes.

7. Never operate with Cutting Head or Folding Section raised if passersby, bystanders, or traffic are in the area to reduce possibility of injury or death from objects thrown by Blades under Guards or mower structure.

8. Before dismounting, secure implement in transport position or lower to ground.

● Put tractor in park or set brake, disengage PTO, stop engine, remove key, and wait until noise of rotation has ceased to prevent crushing by entanglement in rotating parts which could cause injury or death.

● Never mount or dismount a moving vehicle. Crushing from runover may cause serious injury or death.



02967827

Warranty Information: Read and understand the complete Warranty Statement found in this manual. Fill out the Warranty Registration form in full and return it within 90 days. Make certain the Serial Number of the machine is recorded on the Warranty Card, and form that you retain.

FORWARD

This manual contains information about many features of the Tiger mowing and roadside maintenance equipment. Some of these include: Safety precautions, Assembly instructions, Operations, Maintenance and Parts. This manual will also assist you in the proper break-in, daily care, and troubleshooting of your new mower.

We recommend that you read carefully the entire manual before operating the unit. Also, time spent in becoming fully acquainted with its performance features, adjustments, and maintenance schedules will be repaid in a long and satisfactory life of the equipment.

Troubleshooting - Please, before you call, help us to help you!

Please look at the equipment to observe what is happening, then:

- Classify the problem
 - Hydraulic, electrical or mechanical - Read the trouble shooting section
 - Tractor or Truck chassis - Contact vehicle dealer

- If unable to correct the problem yourself, contact your local Tiger Dealer after gathering:
 - Machine model _____
 - Serial number _____
 - Dealer name _____
 - Detailed information about the problem including results of troubleshooting

Attention Owner / Operator / Dealer: It is your obligation to read, and understand, the warranty information section located at the back of this manual denoting that the purchaser understands the safety issues relating to this machine and has received and will read a copy of this manual.

If at any time, you have a service problem with your Tiger mower, Contact your local dealer for service and parts needed.

MANUFACTURED BY:

Tiger Corporation

3301 N. Louise Ave.

Sioux Falls, SD 57107

1-800-843-6849

1-605-336-7900

www.tiger-mowers.com

DISTRIBUTED BY:

1-_____-_____-_____

1-_____-_____-_____

TABLE OF CONTENTS

SAFETY _____	1-1
Safety Information_____	1-2
ASSEMBLY / MOUNTING SECTION _____	2-1
OPERATION SECTION _____	3-1
MAINTENANCE SECTION _____	4-1
PARTS SECTION _____	5-1
Parts Ordering Guide_____	5-2
Parts Table of Contents_____	5-3
Common Parts Section _____	6-1
WARRANTY INFORMATION _____	7-1



1012

This symbol means:

CAUTION – YOUR SAFETY IS AT RISK!

When you see this symbol, read and follow the associated instructions carefully or personal injury or damage may result.

Tiger is a registered trademark.



SAFETY SECTION

SAFETY

General Safety Instructions and Practices

A safe and careful operator is the best operator. Safety is of primary importance to the manufacturer and should be to the owner / operator. Most accidents can be avoided by being aware of your equipment, your surroundings, and observing certain precautions. The first section of this manual includes a list of Safety Messages that, if followed, will help protect the operator and bystanders from injury or death. Read and understand these Safety Messages before assembling, operating or servicing this mower. This equipment should only be operated by those persons who have read the Manual, who are responsible and trained, and who know how to do so safely and responsibly.



1000

The Safety Alert Symbol combined with a Signal Word, as seen below, is used throughout this manual and on decals which are attached to the equipment. The Safety Alert Symbol means: “**ATTENTION! BECOME ALERT! YOUR SAFETY IS INVOLVED!**” The symbol and signal word are intended to warn the owner / operator of impending hazards and the degree of possible injury when operating this equipment.

Practice all usual and customary safe working precautions and above all -- remember safety is up to YOU! Only YOU can prevent serious injury or death from unsafe practices.

DANGER!



Indicates an imminently hazardous situation that, if not avoided, WILL result in DEATH OR VERY SERIOUS INJURY.

WARNING!



Indicates an imminently hazardous situation that, if not avoided, COULD result in DEATH OR SERIOUS INJURY.

CAUTION!



Indicates an imminently hazardous situation that, if not avoided, MAY result in MINOR INJURY.

IMPORTANT!

Identifies special instructions or procedures that, if not strictly observed, could result in damage to, or destruction of the machine, attachments or the environment.

NOTE: *Identifies points of particular interest for more efficient or convenient operation or repair.* (SG-1)

READ, UNDERSTAND, and FOLLOW the following Safety Messages. Serious injury or death may occur unless care is taken to follow the warnings and instructions stated in the Safety Messages. Always use good common sense to avoid hazards. (SG-2)

SAFETY INSTRUCTIONS



SAFETY

PELIGRO!



Si no lee Ingles, pida ayuda a alguien que si lo lea para que le traduzca las medidas de seguridad. (SG-3)



¡ LEA EL INSTRUCTIVO!

DANGER!



Never operate the Tractor or Implement until you have read and completely understand this Manual, the Tractor Operator's Manual, and each of the Safety Messages found in the Manual or on the Tractor and Implement. Learn how to stop the tractor engine suddenly in an emergency. Never allow inexperienced or untrained personnel to operate the Tractor and Implement without supervision. Make sure the operator has fully read and understands the manuals prior to operation. (SG-4)

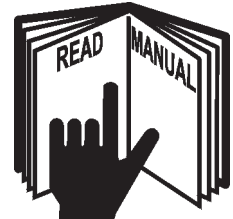

WARNING!



Always maintain the safety decals in good readable condition. If the decals are missing, damaged, or unreadable, obtain and install replacement decals immediately. (SG-5)

WARNING!



Make certain that the "Slow Moving Vehicle" (SMV) sign is installed in such a way as to be clearly visible and legible. When transporting the Equipment use the Tractor flashing warning lights and follow all local traffic regulations. (SG-6)



WARNING!



Operate this Equipment only with a Tractor equipped with an approved roll-over-protective system (ROPS). Always wear seat belts. Serious injury or even death could result from falling off the tractor--particularly during a turnover when the operator could be pinned under the ROPS. (SG-7)



WARNING!



Do not modify or alter this Implement. Do not permit anyone to modify or alter this Implement, any of its components or any Implement function. (SG-8)

DANGER!



BEFORE leaving the tractor seat, always engage the brake and/or set the tractor transmission in parking gear, disengage the PTO, stop the engine, remove the key, and wait for all moving parts to stop. Place the tractor shift lever into a low range or parking gear to prevent the tractor from rolling. Never dismount a Tractor that is moving or while the engine is running. Operate the Tractor controls from the tractor seat only. (SG-9)

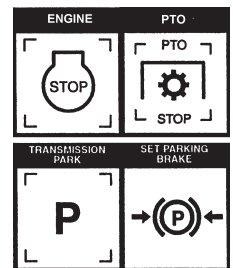

SAFETY

DANGER!



Never allow children or other persons to ride on the Tractor or Implement. Falling off can result in serious injury or death.

(SG-10)



DANGER!



Never allow children to operate or ride on the Tractor or Implement.

(SG-11)



WARNING!



Do not mount the tractor while the tractor is moving. Mount the tractor only when the tractor and all moving parts are completely stopped.

(SG-12)



DANGER!



Start tractor only when properly seated in the tractor seat. Starting a tractor in gear can result in injury or death. Read the tractor operators manual for proper starting instructions.

(SG-13)



DANGER!



Never work under the Implement, the framework, or any lifted component unless the Implement is securely supported or blocked up to prevent sudden or inadvertent falling which could cause serious injury or even death.

(SG-14)



DANGER!



Do not operate this Equipment with hydraulic oil leaking. Oil is expensive and its presence could present a hazard. Do not check for leaks with your hand! Use a piece of heavy paper or cardboard. High-pressure oil streams from breaks in the line could penetrate the skin and cause tissue damage including gangrene. If oil does penetrate the skin, have the injury treated immediately by a physician knowledgeable and skilled in this procedure.

(SG-15)



SAFETY

WARNING!



The operator and all support personnel should wear hard hats, safety shoes, safety glasses, and proper hearing protection at all times for protection from injury including injury from items thrown by the equipment. (SG-16)

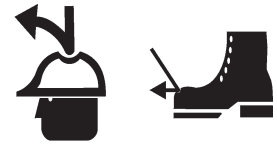

CAUTION!



PROLONGED EXPOSURE TO LOUD NOISE MAY CAUSE PERMANENT HEARING LOSS! Tractors with or without an Implement attached can often be noisy enough to cause permanent hearing loss. We recommend that you always wear hearing protection if the noise in the operator's position exceeds 80db. Noise over 85db over an extended period of time will cause severe hearing loss. Noise over 90db adjacent to the operator over an extended period of time will cause permanent or total hearing loss. *Note:* Hearing loss from loud noise [from tractors, chain saws, radios, and other such sources close to the ear] is cumulative over a lifetime without hope of natural recovery. (SG-17)



WARNING!



Transport only at safe speeds. Serious accidents and injuries can result from operating this equipment at unsafe speeds. Understand the Tractor and Implement and how it handles before transporting on streets and highways. Make sure the Tractor steering and brakes are in good condition and operate properly.



Before transporting the Tractor and Implement, determine the safe transport speeds for you and the equipment. Make sure you abide by the following rules:

1. Test the tractor at a slow speed and increase the speed slowly. Apply the brakes smoothly to determine the stopping characteristics of the Tractor and Implement. As you increase the speed of the Tractor the stopping distance increases. Determine the maximum safe transport speed for you and this equipment.
2. Test the equipment at a slow speed in turns. Increase the speed through the turn only after you determine that it is safe to operate at a higher speed. Use extreme care and reduce your speed when turning sharply to prevent the tractor and implement from turning over. Determine the maximum safe turning speed for you and this equipment before operating on roads or uneven ground.
3. Only transport the Tractor and Implement at the speeds that you have determined are safe and which allow you to properly control the equipment.



Be aware of the operating conditions. Do not operate the Tractor with weak or faulty brakes. When operating down a hill or on wet or rain slick roads, the braking distance increases: use extreme care and reduce your speed. When operating in traffic always use the Tractor's flashing warning lights and reduce your speed. Be aware of traffic around you and watch out for the other guy. (SG-19)

SAFETY

WARNING!



Never attempt to lubricate, adjust, or remove material from the Implement while it is in motion or while tractor engine is running. Make sure the tractor engine is **OFF** before working on the Implement.

(SG-20)



WARNING!



Periodically inspect all moving parts for wear and replace when necessary with authorized service parts. Look for loose fasteners, worn or broken parts, and leaky or loose fittings. Make sure all pins are properly secured. Serious injury may occur from not maintaining this machine in good working order. (SG-21)



WARNING!



Always read carefully and comply fully with the manufacturers instructions when handling oil, solvents, cleansers, and any other chemical agent. (SG-22)



DANGER!



Never run the tractor engine in a closed building or without adequate ventilation. The exhaust fumes can be hazardous to your health.

(SG-23)

DANGER!



KEEP AWAY FROM ROTATING ELEMENTS to prevent entanglement and possible serious injury or death. (SG-24)



DANGER!



Never allow children to play on or around Tractor or Implement. Children can slip or fall off the Equipment and be injured or killed. Children can cause the Implement to shift or fall crushing themselves or others. (SG-25)

SAFETY

DANGER!



NEVER use drugs or alcohol immediately before or while operating the Tractor and Implement. Drugs and alcohol will affect an operator's alertness and coordination and therefore affect the operator's ability to operate the equipment safely. Before operating the Tractor or Implement, an operator on prescription or over-the-counter medication must consult a medical professional regarding any side effects of the medication that would hinder their ability to operate the Equipment safely. **NEVER** knowingly allow anyone to operate this equipment when their alertness or coordination is impaired. Serious injury or death to the operator or others could result if the operator is under the influence of drugs or alcohol. (SG-27)



DANGER!



Operate the Tractor and/or Implement controls only while properly seated in the Tractor seat with the seat belt securely fastened around you. Inadvertent movement of the Tractor or Implement may cause serious injury or death. (SG-29)

WARNING!



Mow only in conditions where you have clear visibility in daylight or with adequate artificial lighting. Never mow in darkness or foggy conditions where you cannot clearly see at least 100 yards in front and to the sides of the tractor and mower. Make sure that you can clearly see and identify passersby, steep slopes, ditches, drop-offs, overhead obstructions, power lines, debris and foreign objects. If you are unable to clearly see this type of items discontinue mowing. (SGM-1)

DANGER!



There are obvious and hidden potential hazards in the operation of this Mower. **REMEMBER!** This machine is often operated in heavy brush and in heavy weeds. The Blades of this Mower can throw objects if shields are not properly installed and maintained. Serious injury or even death may occur unless care is taken to insure the safety of the operator, bystanders, or passersby in the area. Do not operate this machine with anyone in the immediate area. Stop mowing if anyone is within 100 yards of mower. (SGM-2)



DANGER!



All Safety Shields, Guards and Safety devices including (but not limited to) - the Deflectors, Steel Guards, Gearbox Shields, PTO integral shields, and Retractable Door Shields should be used and maintained in good working condition. All safety devices should be inspected carefully at least daily for missing or broken components. Missing, broken, or worn items must be replaced at once to reduce the possibility of injury or death from thrown objects, entanglement, or blade contact. (SGM-3)

SAFETY

DANGER!



The rotating parts of this machine have been designed and tested for rugged use. However, the blades could fail upon impact with heavy, solid objects such as metal guard rails and concrete structures. Such impact could cause the broken objects to be thrown outward at very high velocities. To reduce the possibility of property damage, serious injury, or even death, never allow the cutting blades to contact such obstacles. (SGM-4)

WARNING!



Extreme care should be taken when operating near loose objects such as gravel, rocks, wire, and other debris. Inspect the area before mowing. Foreign objects should be removed from the site to prevent machine damage and/or bodily injury or even death. Any objects that cannot be removed must be clearly marked and carefully avoided by the operator. Stop mowing immediately if blades strike a foreign object. Repair all damage and make certain rotor or blade carrier is balanced before resuming mowing. (SGM-5)



WARNING!



Many varied objects, such as wire, cable, rope, or chains, can become entangled in the operating parts of the mower head. These items could then swing outside the housing at greater velocities than the blades. Such a situation is extremely hazardous and could result in serious injury or even death. Inspect the cutting area for such objects before mowing. Remove any like object from the site. Never allow the cutting blades to contact such items. (SGM-6)

WARNING!



Mow at the speed that you can safely operate and control the tractor and mower. Safe mowing speed depends on terrain condition and grass type, density, and height of cut. Normal ground speed range is from 0 to 5 mph. Use slow mowing speeds when operating on or near steep slopes, ditches, drop-offs, overhead obstructions, power lines, or when debris and foreign objects are to be avoided. (SGM-7)

WARNING!



Avoid mowing in reverse direction when possible. Check to make sure there are no persons behind the mower and use extreme care when mowing in reverse. Mow only at a slow ground speed where you can safely operate and control the tractor and mower. Never mow an area that you have not inspected and removed debris or foreign material. (SGM-8)

WARNING!



Do not put hands or feet under mower decks. Blade Contact can result serious injury or even death. Stay away until all motion has stopped and the decks are securely blocked up. (SGM-9)



DANGER!



Replace bent or broken blade with new blades. NEVER ATTEMPT TO STRAIGHTEN OR WELD ON BLADES SINCE THIS WILL LIKELY CRACK OR OTHERWISE DAMAGE THE BLADE WITH SUBSEQUENT FAILURE AND POSSIBLE SERIOUS INJURY FROM THROWN BLADES. (SGM-10)

WARNING!



Do not mow with two machines in the same area except with Cab tractors with the windows closed. (SGM-11)

SAFETY

DANGER!



Rotary Mowers are capable under adverse conditions of throwing objects for great distances (100 yards or more) and causing serious injury or death. Follow safety messages carefully.

STOP MOWING IF PASSERSBY ARE WITHIN 100 YARDS UNLESS:

- Front and Rear Deflectors are installed and in good, working condition;
- Mower Head is running close to and parallel to the ground without exposed Blades;
- Passersby are outside the existing thrown-object zone;
- All areas have been thoroughly inspected and all foreign material such as rocks, cans, glass, and general debris has been removed.



NOTE: Where there are grass and weeds high enough to hide debris that could be struck by the blades, the area should be: inspected and large debris removed, mowed at an intermediate height, inspected closely with any remaining debris being removed, and mowed again at desired final height. (SFM-6)

WARNING!



Each Rear Wheel must have a minimum of 1,000 pounds contact with the surface to prevent lateral instability and possible tip-over which could result in serious bodily injury or even death. Widen the wheel tread and add weights if needed. Refer to the mounting instructions or call Customer Service if you need assistance with Counterweight Procedure. (SFL-3)



WARNING!



Do not operate Mower if excessive vibration exists. Shut down PTO and the Tractor engine. Inspect the Mower to determine the source of the vibration. If Mower blades are missing or damaged replace them immediately. Do not operate the mower until the blades have been replaced and the Mower operates smoothly. Operating the Mower with excessive vibration can result in component failure and broken objects to be thrown outward at very high velocities. To reduce the possibility of property damage, serious injury, or even death, never allow the Mower to be operated with blades missing. (SFL-4)

WARNING!



Do not let the Blades turn when the Mower Deck is raised for any reason, including clearance or for turning. Raising the Mower deck exposes the Cutting Blades which creates a potentially serious hazard and could cause serious injury or even death from objects thrown from the Blades. (SRM-7)



WARNING!



Never leave Tractor and Implement unattended while the implement is in the lifted position. Accidental operation of lifting lever or a hydraulic failure may cause sudden drop of unit with injury or death by crushing. To properly park the implement when disconnecting it from the tractor, lower the stand and put the retaining pin securely in place, or put a secure support under the A-Frame. Lower the implement carefully to the ground. Do not put hands or feet under lifted components. (SPT-1)

SAFETY

WARNING!



Be particularly careful when transporting the Implement with the Tractor. Turn curves or go up hills only at a low speed and using a gradual steering angle. Rear mounted implements move the center of gravity to the rear and remove weight from the front wheels. Make certain, by adding front ballast, that at least 20% of the tractor's weight is on the front wheels to prevent rearing up, loss of steering control or Tractor tip-over. Slow down on rough or uneven surfaces to prevent loss of steering control which could result in property damage or possible injury. Do not transport unless 3-Point lift lever is fully raised and in the latched transport position. Dropping implement in transport can cause serious damage to the tractor and/or Implement and possibly cause the operator or others to be injured or killed. (S3PT-2)

WARNING!



The rotating parts of this machine continue to rotate even after the Tractor has been turned off. The operator should remain in his seat for 60 seconds after the brake has been set, the PTO disengaged, the tractor turned off, and all evidence of rotation has ceased. (SBM-5)

“Wait a minute...Save a life!”

DANGER!



There are obvious and hidden potential hazards in the operation of this Implement as in all power-driven or pulled equipment. REMEMBER! This machine is often operated in rough terrain conditions that include tall grass, weeds, gullies, holes, slopes, hidden obstructions and the like. Serious injury or even death may occur unless care is taken to assure the safety of the operator and bystanders in the area. Do not operate this machine with anyone in the immediate area. (S3PT-7)

WARNING!



Relieve hydraulic pressure prior to doing any maintenance or repair work on the Implement. Place the Implement on the ground or securely blocked up, disengage the PTO, and turn off the tractor engine. Push and pull the Remote Cylinder lever in and out several times prior to starting any maintenance or repair work. (S3PT-9)



DANGER!



This Implement is wider than the Tractor. Be careful when operating or transporting this equipment to prevent the Implement from running into or striking sign posts, guard rails, concrete abutments or other solid objects. Such an impact could cause the Implement and Tractor to pivot violently resulting in loss of steering control, serious injury, or even death. Never allow the Implement to contact obstacles. (S3PT-12)

DANGER!



The flail cutter shaft is designed for standard rotation (same rotation as the tractor wheels during forward travel). **Never operate the cutter shaft in the reverse rotation.** Operating this mower in reverse rotation may cause objects to be thrown out the front of the mower head.

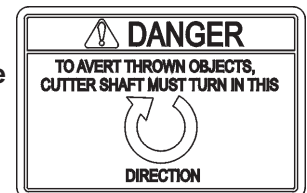

SAFETY

WARNING!



Engine Exhaust, some of its constituents, and certain components contain or emit chemicals known to the state of California to cause cancer and birth or other reproductive harm.

WARNING!



Battery posts, terminals and related accessories contain lead and lead compounds, chemicals known to the state of California to cause cancer and birth or other reproductive harm. **Wash hands after handling!**

Tiger mowers use balanced and matched system components for blade carriers, blades, cutter-shafts, knives, knife hangers, rollers, drive-train components and bearings. These parts are made and tested to Tiger specifications. Non-genuine “will fit” parts do not consistently meet these specifications. The use of “will fit” parts may reduce mower performance, void mower warranties and present a safety hazard. Use genuine Tiger mower parts for economy and safety.

SEE YOUR  DEALER

In addition to the design and configuration of this Implement, including Safety Signs and Safety Equipment, hazard control and accident prevention are dependent upon the awareness, concern, prudence, and proper training of personnel involved in the operation, transport, maintenance, and storage of the machine. Refer also to Safety Messages and operation instruction in each of the appropriate sections of the Tractor and Equipment Manuals. Pay close attention to the Safety Signs affixed to the Tractor and Equipment. (SG-18)

SAFETY

DO NOT LUBRICATE WITH AUTOMATIC GREASE GUN. GREASE WITH HAND GREASE GUN ONLY.

P/N22839

PART NO.
LOCATION

22839
MOWER DECK



22840
INSIDE OF CAB



24028

24028
MOWER DECK



10" x 5.5" 31522
MOWER DECK
18.25" x 10" 31523
HYDRAULIC TANK

SAFETY

PART NO.
LOCATION



42350
MOWER DECK

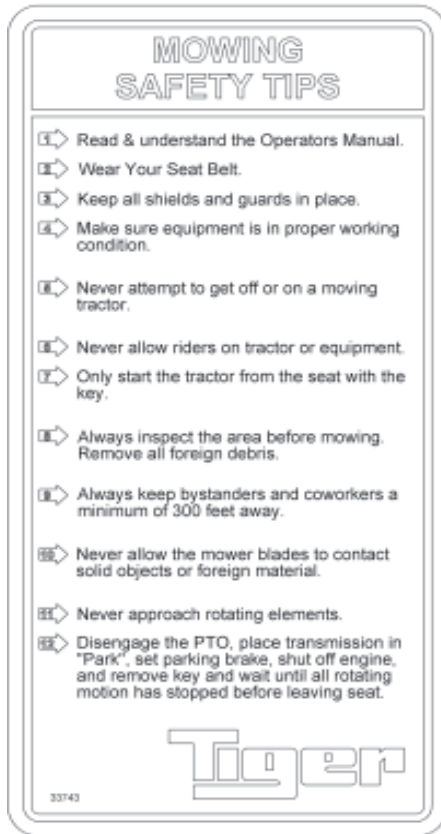

33743
INSIDE OF CAB



42399
MOWER DECK



42400
MOWER DECK

SAFETY



PART NO.
LOCATION

6T3217
MOWER DECK



6T3219
INSIDE OF CAB

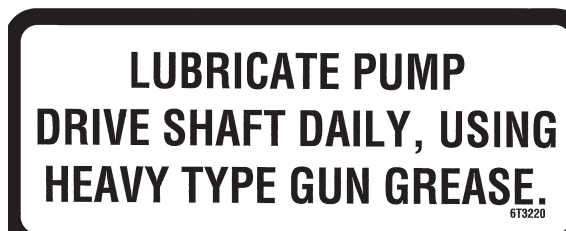

6T3220
FRONT PUMP MOUNT



6T3221
INSIDE OF CAB

SAFETY

NOTICE:
Engine will not start when mower is engaged.

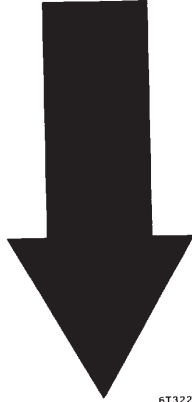

6T3222

PART NO.
LOCATION

6T3222
INSIDE OF CAB

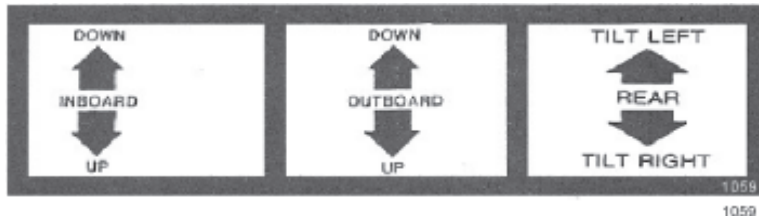

INSIDE OF CAB



6T3224
MOWER DECK

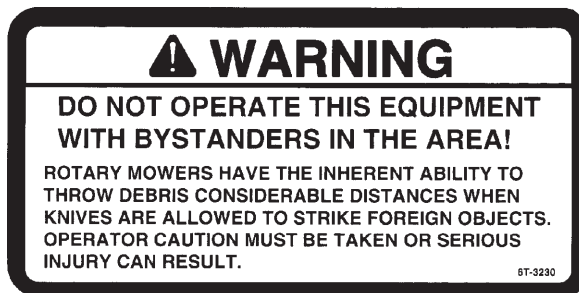

6T3230
INSIDE OF CAB

SAFETY

PART NO.
LOCATION



6T3233
HYDRAULIC TANK



6T3234
INSIDE OF CAB



6T3236
MOWER DECK
HYDRAULIC TANK



6T3243
INSIDE OF CAB

SAFETY

PART NO.
LOCATION

GREASING INSTRUCTIONS
CUTTER SHAFT BEARING
GREASE EVERY 8 HRS. OR DAILY

NOTE: If unusual environmental conditions exist-extreme temperatures, moisture, or contaminants-more frequent lubrication is required.

6T3249A

6T3249A
MOWER DECK

GREASING INSTRUCTIONS
GROUND ROLLER BEARING
GREASE EVERY 8 HRS. OR DAILY

NOTE: If unusual environmental conditions exist-extreme temperatures, moisture, or contaminants-more frequent lubrication is required.

6T3261

6T3261
MOWER DECK

 **WARNING**

**DO NOT OPERATE MOWER
WITH SAFETY SHIELD REMOVED.**

TB1011

TB1011
MOWER DECK

SAFETY



Tiger Corporation

800-843-6849

www.tiger-mowers.com

Description	Application	General Specification	Recommended Lubricant
Tractor Hydraulics	Reservoir	JD-20C	Mobilfluid® 424
Mower Hydraulics Cold Temperatures 0°F Start-up Normal Temperatures 10°F Start-up Normal Temperatures 15°F Start-up High Operating Temperatures Above 90°F Ambient	Reservoir	ISO 46 Anti-Wear/ Low Temp JD-20C ISO 46 Anti-Wear ISO 100 Anti-Wear	Mobil DTE® 15M Mobilfluid® 424 Mobil DTE® 25 Mobil DTE® 18M
Flail Rear Gearbox	Reservoir	PAO Synthetic Extreme Pressure Gear Lube	Mobilube SHC® 75W-90, Mobil 1 Synthetic Gear Lubricant
Cutter Shaft and Ground Roller Shaft (Flail)	Grease Gun	Lithium Complex, NLGI 2 ISO 320	Mobilgrease® CM-S
Drive Shaft Coupler (Rotary and Flail)	Grease Gun	Lithium Complex, NLGI 2 ISO 320	Mobilgrease® CM-S
Boom Swivel, Boom Cylinder Pivots (Rotary and Flail Boom Type)	Grease Gun	Lithium Complex, NLGI 2 ISO 320	Mobilgrease® CM-S
Deck Boom Pivot & Deck Stop Adjustment (Rotary and Flail)	Grease Gun	Lithium Complex, NLGI 2 ISO 320	Mobilgrease® CM-S
Deck Spindle (Rotary)	Grease Gun	Tiger Spindle Lubricant	Mobilith SHC 220

For Mobil product information, availability, or technical information, call 1-800-862-4525.

Tiger PN 34852

34852
HYDRAULIC TANK

SAFETY

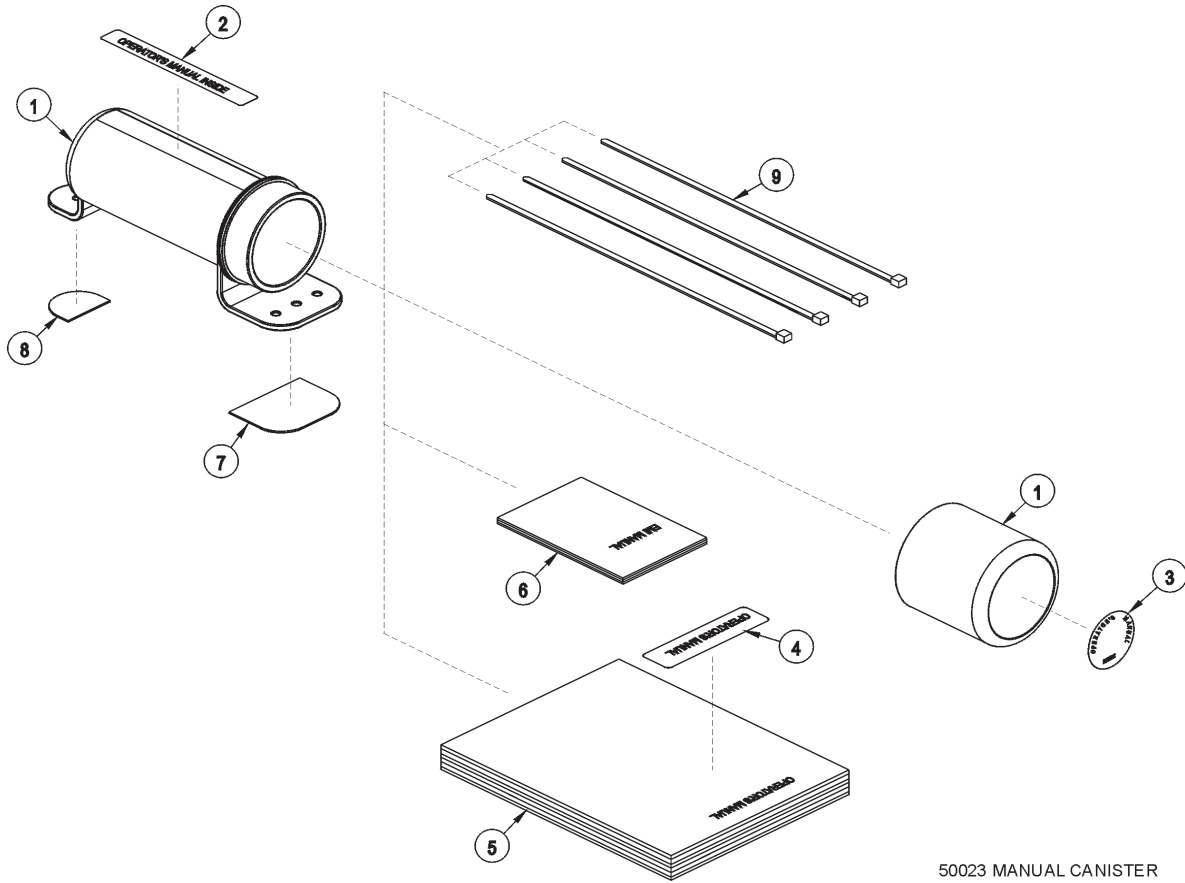

ITEM	PART NO.	QTY.	DESCRIPTION
	50023	AVAIL	MANUAL CANISTER COMPLETE
1	00776031	1	ROUND MANUAL CANISTER
2	33997	1	DECAL, SHEET, MANUAL CANISTER
3		*	DECAL
4		*	DECAL
5	*	AVAIL	SPECIFIC PRODUCT MANUAL
6	33753	1	E M I SAFETY MANUAL
7	34296	1	FRONT ADHESIVE PAD
8	34297	1	REAR ADHESIVE PAD
9	6T1823	4	ZIPTIE 14" LONG

NOTE:

The manual canister can be bolted, zip tied or adhered to a variety of surfaces. Locate a protected area within the view of the operator. Then select an installation method and attach the canister. **CAUTION - AVOID DRILLING HOLES INTO UNKNOWN AREAS**, wires and other parts may be located behind these areas. When adhering the canister to a surface, thoroughly clean that surface before installing the canister.

SAFETY

FEDERAL LAWS AND REGULATIONS

This section is intended to explain in broad terms the concept and effect of federal laws and regulations concerning employer and employee equipment operators. This section is not intended as a legal interpretation of the law and should not be considered as such.

Employer-Employee Operator Regulations

U.S. Public Law 91-596 (The Williams-Steiger Occupational and Health Act of 1970) OSHA

This Act Seeks:

“...to assure so far as possible every working man and woman in the nation safe and healthful working conditions and to preserve our human resources...”

DUTIES

Sec. 5 (a) Each employer-

(1) shall furnish to each of his employees employment and a place of employment which are free from recognized hazards that are causing or are likely to cause death or serious physical harm to his employees;

(2) shall comply with occupational safety and health standards promulgated under this Act.

(b) Each employee shall comply with occupational safety and health standards and all rules, regulations and orders issued pursuant to this Act which are applicable to his own actions and conduct.

OSHA Regulations

OSHA regulations state in part: “At the time of initial assignment and at least annually thereafter, the employer shall instruct every employee in the safe operation and servicing of all equipment with which the employee is, or will be involved.”

Employer Responsibilities:

To ensure employee safety during Tractor and Implement operation, it is the employer's responsibility to:

1. Train the employee in the proper and safe operation of the Tractor and Implement.
2. Require that the employee read and fully understand the Tractor and Implement Operator's manual.
3. Permit only qualified and properly trained employees to operate the Tractor and Implement.
4. Maintain the Tractor and Implement in a safe operational condition and maintain all shields and guards on the equipment.
5. Ensure the Tractor is equipped with a functional ROPS and seat belt and require that the employee operator securely fasten the safety belt and operate with the ROPS in the raised position at all times.
6. Forbid the employee operator to carry additional riders on the Tractor or Implement.
7. Provide the required tools to maintain the Tractor and Implement in a good safe working condition and provide the necessary support devices to secure the equipment safely while performing repairs and service.

Child Labor Under 16 Years of Age

Some regulations specify that no one under the age of 16 may operate power machinery. It is your responsibility to know what these regulations are in your own area or situation. (Refer to U.S. Dept. of Labor, Employment Standard Administration, Wage & Home Division, Child Labor Bulletin #102.)

ASSEMBLY SECTION

ASSEMBLY

Before attempting to mount your Tiger mower, it is important to read and understand all of the Safety Messages in the Safety section of this manual.

Check complete shipment list against the packing list to make sure there are no shortages. Make certain the tractor model is the appropriate one for the mower received!

WARNING!



Always use a floor jack, hoist or fork lift to lift and raise heavy parts.

Read and understand the entire assembly section instructions before attempting to mount your Tiger mower. Refer to the parts section of this manual for detailed illustrations to locate all parts.

TRACTOR PREPARATION

- A: Remove right hand steps.
- B: Disconnect battery cables from both batteries.
- C: Remove engine side panels, or raise hood to access front pulley.
- D: Remove plugs from tractor casting where main frame and pump mount will be attached.
- E: Remove any front weights and weight supports.
- F: Raise the tractor onto jack-stands and remove the right rear wheel.

CRANKSHAFT ADAPTER

If necessary remove the four capscrews from the crankshaft pulley. Then install the crankshaft adapter plate to the pulley with capscrews and lockwashers as shown in the parts section.

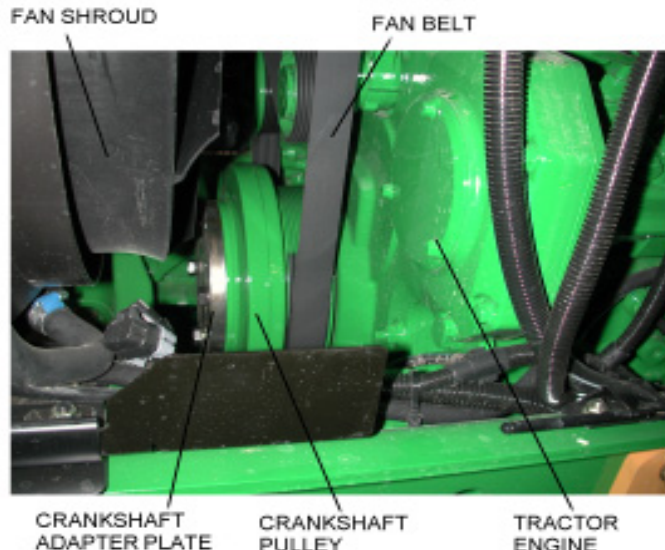

ASSEMBLY

FRONT CRANKSHAFT PULLEY

John Deere has changed to a **new** tier two engine on all 6000 series tractors. With the change, Tiger has found that the front crankshaft pulley used by JD will not allow for the installation of a front drive system. With the change on the 6X15 and 6X20 series tractors, you will need to order a different pulley, washer and bolt from John Deere to allow for a front drive to be installed on your tractor.

Inspect the front pulley on your tractor to verify you have the correct pulley needed to mount the spacer plate. If your pulley has the (4) four holes needed to mount the spacer, your pulley is the correct one needed. If your pulley does not have the (4) four holes in the pulley, you will need to order the correct pulley, washer and bolt from John Deere.

PARTS REQUIRED TO PURCHASE FROM JOHN DEERE:

Pulley from JD – R516320

Washer from JD – R517237

Bolt from JD – R516648

Torque on the pulley bolt with locktite is 369 lb-ft.*

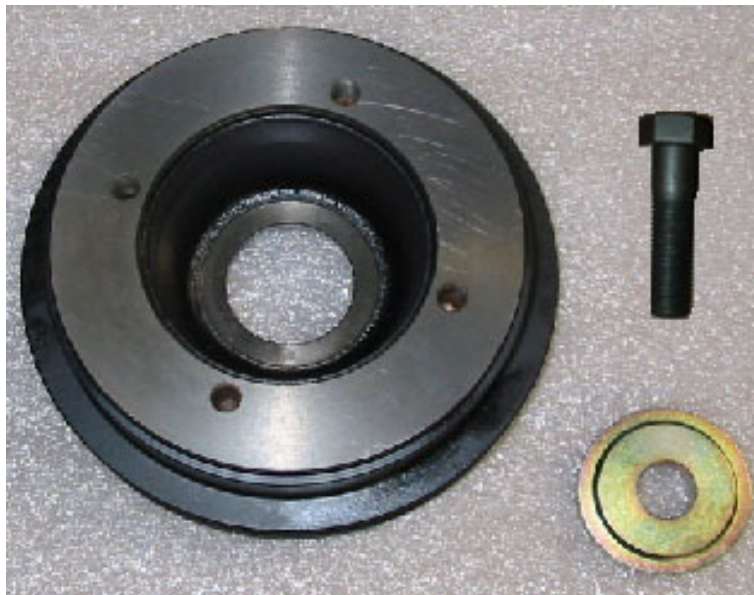

Solution:

1. Clean nose of crankshaft using TY16285 clean and cure primer.
2. Apply a light 2-3 mm bead of TY15969 retaining compound around the leading edge of the crankshaft nose.
3. Dip damper mounting caps crew in clean SAE30 engine oil (Always use a new cap screw)
4. Position damper/pulley on the crankshaft and thread cap screw up tight (do not rely on the cap screw to pull the pulley straight onto the taper)
5. Tighten cap screw to specification 500Nm (369lb-ft) (the engine will most likely have to be pinned)
6. Measure run-out on the pulley, spec is 0.003" or less

ASSEMBLY

CABLE CONTROL LEVER STAND

On the corner cab post, mark a point at 1-3/8" from the windshield and 22 1/2" from the floor; then cut a 3/4" diameter hole through the outer plastic shell. This will expose a threaded steel boss to attach the control box support bracket.

The rear corner of the cable control stand is placed approximately 5 3/4" from the edge of the mat. The front edge of the stand is up against the corner cab post and the door sill lip of the mat. Before you mark or drill any holes, check for support plates or wires under the mat & the cab floor. **NOTE:** Cutting into plates or wires makes more work for everyone and could be dangerous. When you know where the wires/plates lie, mark one of the mounting holes. Drill a 3/8" hole through the mat and through the floor of the cab. Next, lift the mat up and mark the other two holes on the cab floor. Drill the holes through the floor. Mark the mat and drill the other two 3/8" holes. Use a 1" hole saw and cut a 1" hole through the mat over each 3/8" hole. Secure the stand to the floor with the spacers, capscrews and nylock nuts provided.

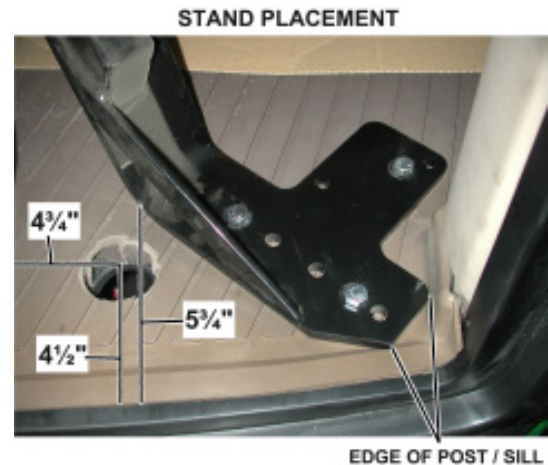

UNDER FLOOR OF CAB

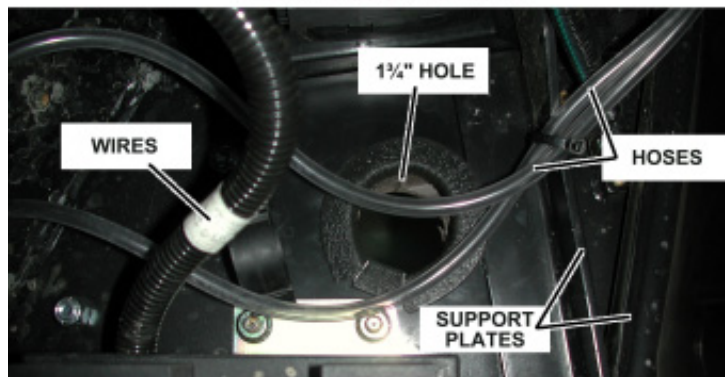

Cut a 1 3/4" hole in the floor to route the cables and wires through. It needs to have a 1/4" clearance for the trim lock. Before you mark or drill any holes, check for support plates or wires under the cab floor.

NOTE: Cutting into plates or wires makes more work for everyone and could be dangerous. Look under the floor for cables and plates that you need to avoid. The hole should be approximately 4 1/2" from the door sill and 4 3/4" from the lip of the mat under the console. Install the trim lock around the metal edges of the hole, then route the control cables and wires through the hole.



Next, wrap the cables with the 6" split hose at the point they pass through the hole, and secure the zip-ties. Apply RTV sealer in and around individual cables and split hose, inside and outside of the cab for a water tight seal. Install upper support bracket from cab post to the control lever stand.

ASSEMBLY

CABLE SWITCH BOX WIRING

Refer to the parts section for wiring diagram to hook up the switch box. Cover all the wires from the switch box with plastic wire wrap provided. Route the wires from the switch box to the front console panel as shown on previous page. Remove the console panel under the steering wheel to access tractor wires. Locate the blue colored wire. **Using a test light or meter to verify** this wire is the neutral safety wire. Cut the blue wire and connect the green wires from the switch box as shown in the wiring diagram.

To run the white wire to the solenoid valve, you will need to drill a hole in the front edge of the cab floor on the right side of the front console. Insert a rubber grommet into the hole to protect the wire, and route the wire out of the cab.

The red wire is to be hooked to the tractor ignition switch or an available slot in the fuse box. **NOTE: +12 VOLTS ELECTRICAL POWER MUST BE TAKEN FROM A SOURCE LOCATION WHERE IT IS LIVE ONLY WHEN THE IGNITION SWITCH IS IN THE "ON" POSITION. THIS WIRE MUST BE FUSED AT THE SOURCE LOCATION**

The travel lock red wire from the switch box should also run with the white wire through the rubber grommet and be covered with wire wrap. This wire will be connected to the electronic travel lock located on the main boom cylinder. The wires from the switch box are longer than needed and should be carefully cut and spliced as required. Zip ties should be used to secure the wires to the tractor framework and boom hoses to eliminate vibration and rubbing.

Cut slot in right side panel of steering column to run wires from switch box.
NOTE: When cutting or drilling hole, be sure not to damage existing wires running behind panels.



CUT SLOT IN PANEL FOR WIRES FROM SWITCH BOX TO ENTER STEERING COLUMN

1244

ASSEMBLY

CABLE VALVE MOUNTING PLATE (CAB)

Align the mounting bracket to the existing holes on top of the tractor remote valve at the rear of the tractor. Secure the bracket to the tractor with hardware shown in the parts section of the manual. Attach the valve mounting plate to the valve mounting bracket on the rear to the tractor as shown below. Then place and secure the lift valve on top of the mounting plate. Install the control cables and route the hydraulic lines from the lift valve to the hydraulic cylinders as noted on the lift valve page of the parts section.

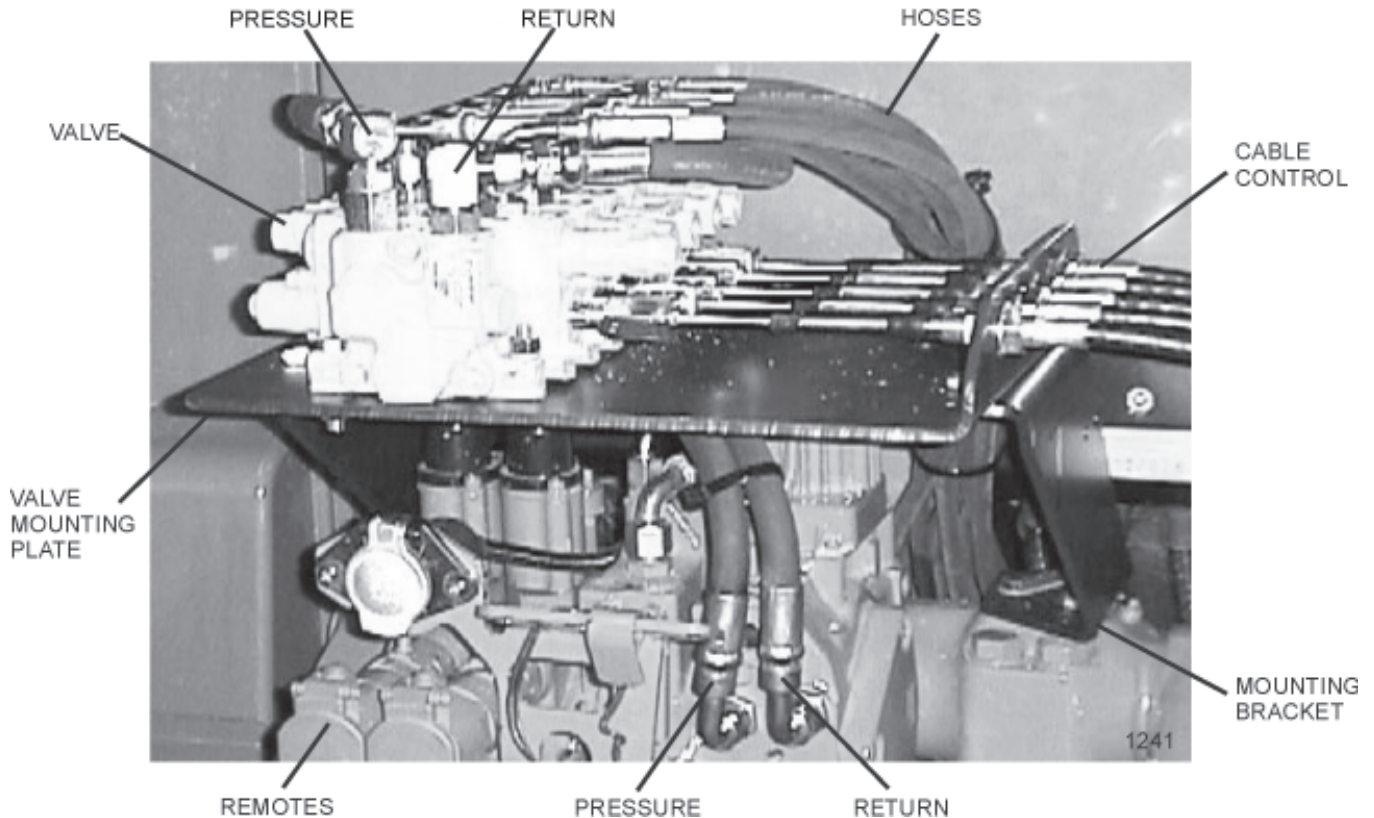

ASSEMBLY

ORIGINAL END CAP

PRESSURE LINE INSTALLATION

The hydraulic pressure line will be plumbed into the rear of the tractor remote valve end cap. Locate the pressure port and remove the plug (refer to the illustration below and the Parts Section pages for position of the pressure port). After the plug is removed then install 22mm adapter. Next connect a 1/2" FJX x 1/2" FJX 90 hose from the tractor remote valve to the Tiger valve.

RETURN LINE INSTALLATION

The return line will be plumbed in next to the pressure line in the tractor remote valve end cap. Locate the return port and remove the plug (refer to the illustration below and the Parts Section for the position of the return port). After the plug is removed then install 22mm adapter. Next connect a 1/2" FJX x 1/2" FJX 90 hose from the tractor remote valve to the Tiger valve.

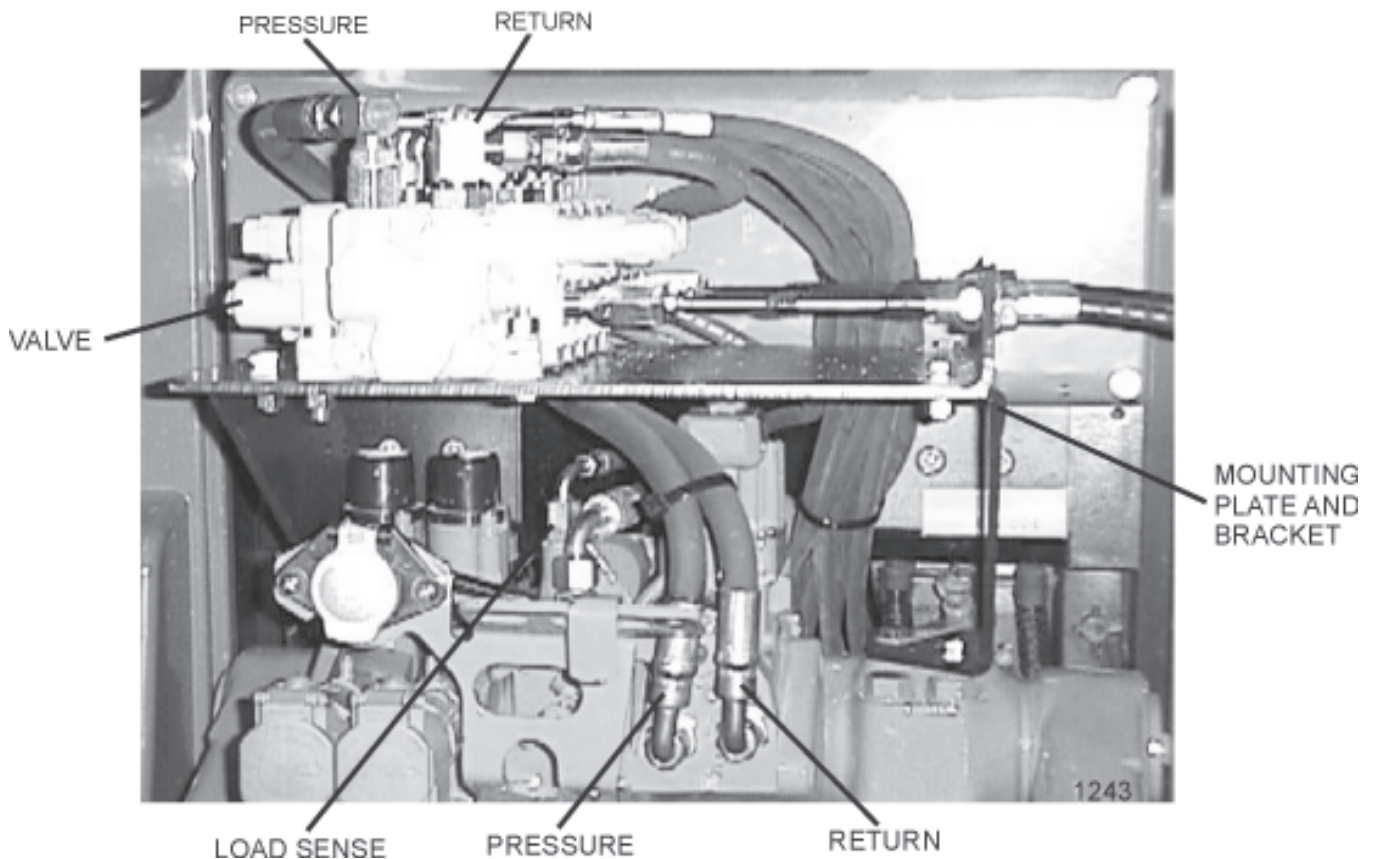

ASSEMBLY

LOAD SENSE LINE INSTALLATION

To install the load sense lines from a Husco valve to the tractor remote valve, first the existing load sense line located on the top of the tractor remote valve connecting “load sense -1” and “load sense -2” must be removed, in order so that the two load sense lines are able to be connected to the Husco valve. Next connect a 1/4” hose (load sense - 1) to the tractor remote valve and to the top front port on the Husco valve. Next connect a 1/4” (load sense - 2) to the tractor remote valve and to the port to the lower right of the “load sense-1” line on the Husco valve.

For more information refer to the Parts Section pages for a complete diagram of the tractor valve hookup.

2004 END CAP UPDATE

PRESSURE LINE INSTALLATION

The hydraulic pressure line will be plumbed into the rear of the tractor remote valve end cap. Locate the pressure port on the end cap and remove the plug (refer to the illustration below and the Parts Section pages for position of the pressure port). After the plug is removed then install 22mm adapter. Next connect a 1/2” hose from the tractor remote valve to the Tiger valve.

RETURN LINE INSTALLATION

The return line will be plumbed in next to the pressure line in the tractor remote valve end cap. Locate the return port and remove the plug (refer to the illustration below and the Parts Section for the position of the return port). After the plug is removed then install 22mm adapter or elbow. Next connect a 1/2” hose from the tractor remote valve to the Tiger valve.

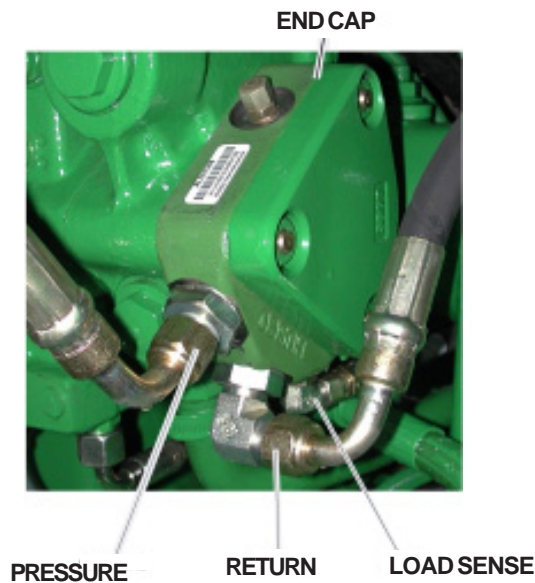

ASSEMBLY

HUSCO LOAD SENSE LINE INSTALLATION

To install the load sense line from a Husco valve to the tractor remote valve, first locate the load sense port located on the bottom of the end cap. Remove the plug and install 14mm elbow, then attach the 1/4" hose to the end cap and to the top front port on the Husco valve.

For more information refer to the Parts Section pages for a complete diagram of the tractor valve hookup.

LOAD SENSE END

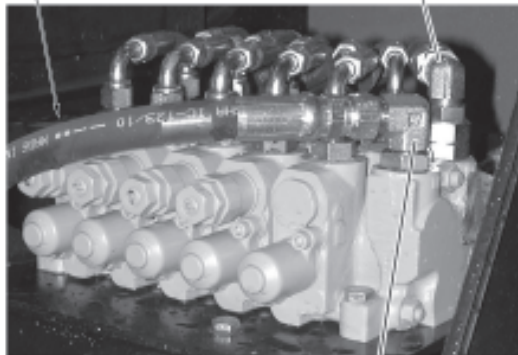

PRESSURE

RETURN

HUSCO VALVE

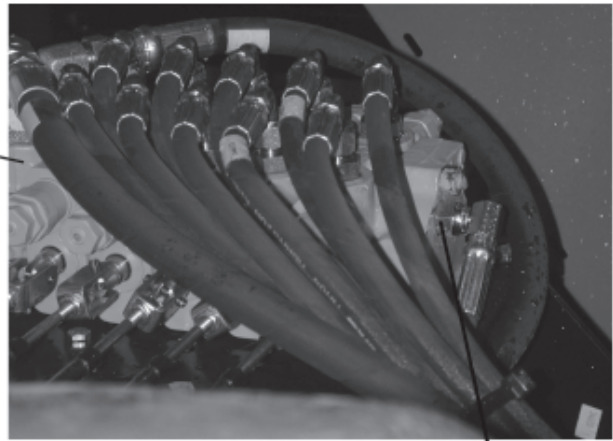

LOAD SENSE

2004 UPDATES APPLY TO THESE MODEL'S

JD6000 SERIES SERIAL #'S WITH THIS CHANGE: 391333, 391640, 392239, 395891, 396190, 397161, 396515, 396572, 396560, 396777, 396754, 396764, 396981, 397327, 396983, 396987, 397165, 397159, 397211, 397773, 397450, 397354, 397341, 397498, 397527, 397520, 397360, 397475, 397538, 397569, 397554, 397545, 397585, 397506, 397570, 397587, 397575, AND MODEL #'S STARTING WITH #398797.

JD7000 SERIES SERIAL#'S WITH THIS CHANGE START AT: 12451

INSTALLING NATIONAL PIPE FITTINGS

Whenever installing a pipe fitting, wrap the threads clockwise (looking at the end) with teflon tape. In this way, the tape will be tightened when installed. NOTE: It is not necessary to tape O-ring fittings, or those installed in swivels.

ASSEMBLY

INSTALLING O-RING FITTINGS

Installing straight, 45 degree and 90 degree O-ring fittings requires that the O-ring, washer and nut (A) be up against the swivel body (B). Insert the swivel and turn in until the swivel is pointed in the right direction and O-ring contact is made. Hold swivel in set direction with a wrench and turn the O-ring nut away from the swivel body and carefully tighten.

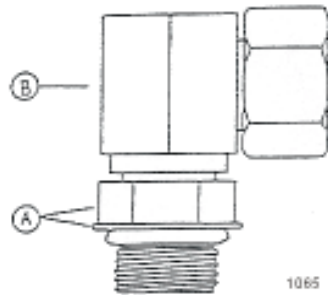

MANUAL VALVE MOUNTING (WO/CAB)

Refer to the parts section, lift valve page for hardware and location of components. First, attach control valve stand to the top of the main frame mast with cap-screws, lock-washers and hex nuts. NOTE: The mounting plate should face the rear of the tractor.

Attach the 3-spool control valve to the stand using the hardware noted in the parts section. One cap-screw must be used to secure the switch box to the under side of the valve stand.

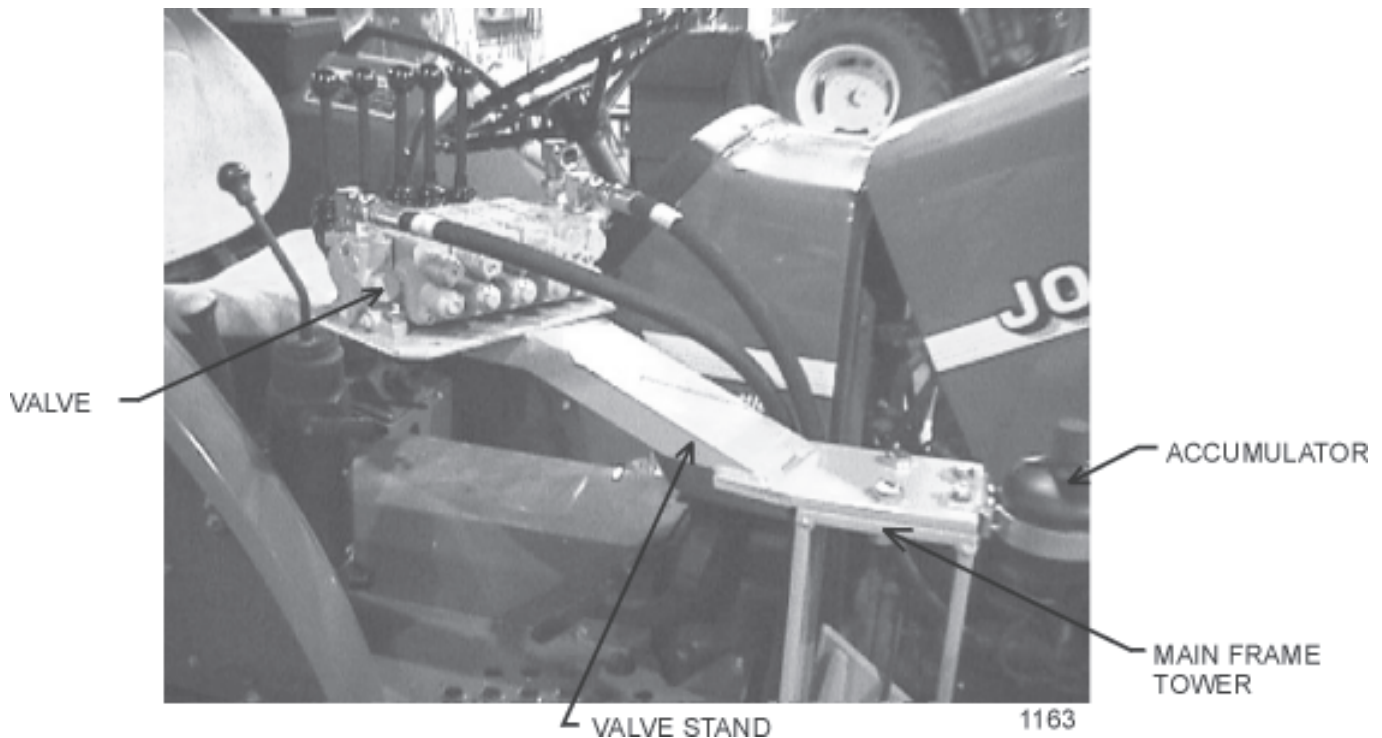

ASSEMBLY

MANUAL SWITCH MOUNTING

Refer to the parts section for wiring diagrams. Remove right side cowl panel, tach panel, and hour meter panel for access to the wires.

Route the red wire from the switch box to the bare electrical plug in the fuse box, or other un-used "keyed" hot wire. **NOTE: +12 VOLTS ELECTRICAL POWER MUST BE TAKEN FROM A SOURCE LOCATION WHERE IT IS LIVE ONLY WHEN THE IGNITION SWITCH IS IN THE "ON" POSITION. THIS WIRE MUST BE FUSED AT THE SOURCE LOCATION.**

Drill a ½" hole in the 9" X 5" right side panel to route the green safety switch wires, and white wire to be connected to the hydraulic solenoid valve.

The switch box is to be secured to the operators side of the control handles, or valve stand.

The green wires will connect to the neutral safety switch blue wires, located on the back of the ignition switch, under the cowl panel.



TEMPERATURE GAUGE MOUNTING

(OPTIONAL)

Mount the temperature gauge where it is clearly visible to the operator. Attach the green (-) wire from the negative post on the gauge to a grounded bolt on the tractor frame. Remove paint if needed to make a good ground. Remove the pipe plug from the side of the hydraulic reservoir, and install the temperature sensor using thread sealing tape. Run the white wire from the (s) sensor post of the gauge to the temperature sensor on the hydraulic reservoir tank.

ASSEMBLY

TWIN ROTARY HYDRAULIC DIAGRAM

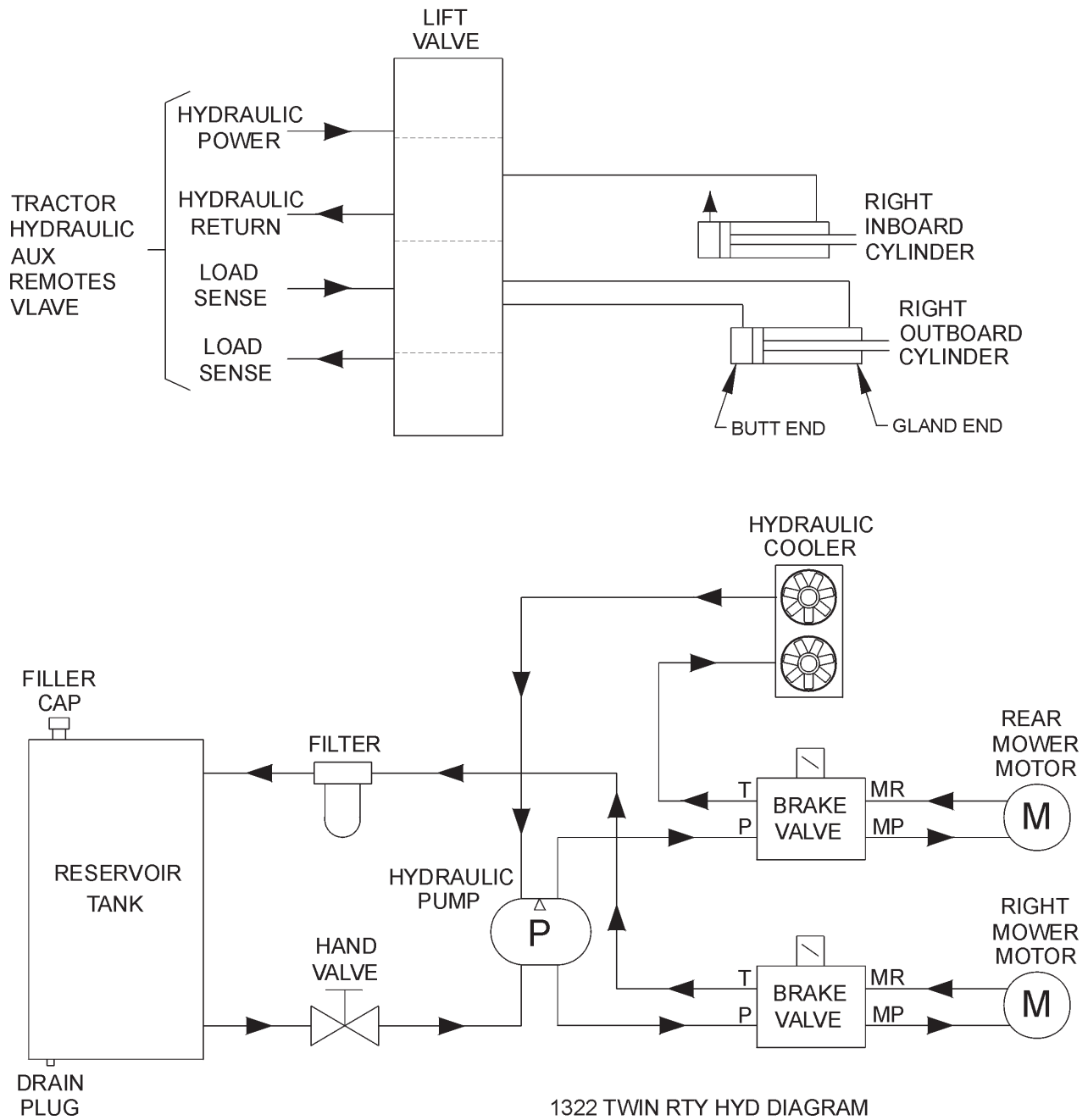

ASSEMBLY

MAIN FRAME MOUNTING

Raise front of tractor as needed and slide the main frame under tractor from right hand side. With an overhead hoist and / or jack-stands, raise the frame up to the correctly matching mounting holes. Install cap-screws and all other hardware as shown in main frame parts section. Remove the cap-screws one at a time and apply a thread locking agent, then reinsert the cap-screws and tighten / torque to values noted in the torque chart located in the maintenance section of this manual.

HYDRAULIC TANK INSTALLATION

Install all fittings and tubes into tank and tank filter as shown in parts section illustration. Insert tank sight glass into front side of the tank. Install the temperature sensor or pipe plug into the side of the tank.

Place the tank in the mounting bracket on the main frame with fittings toward tractor and filter toward the cab.

Secure the tank in the mounting bracket with the tank strap and nylock nuts.

Install the filter gauge into the filter housing so that it points to the rear of the tractor and is clearly visible to the operator.

Locate the tank breather and reducer bushing (bushing may be already installed in the tank along with many of the for-mentioned parts). These will be installed after tank is filled.

DRIVESHAFT & FRONT PUMP MOUNTING

Install spacer plate on tractor engine using bolts and lockwashers as shown in parts section. Grease sleeve section of the driveshaft and install from the side of the engine compartment. Once you have the sleeve section in place, bolt to spacer plate using bolts and lockwashers as shown in parts section. Install shaft end of driveshaft through opening and into driveshaft sleeve. Shaft and sleeve yokes should be aligned, if shaft does not insert easily in sleeve, turn shaft 180°, and then install. **Shaft end must be installed in correct orientation, failure to do so may result in damage to tractor and/or driveshaft.** After installation of shaft end, install pump mount. Next, install pump. After pump is secured, install driveshaft in to pump shaft. The end of driveshaft should be no more than 1/2" away from contact with pump housing. Tighten crimping bolt on driveshaft. Lube driveshaft & check all hoses, flanges, the pump, pump mount, driveshaft and mounting plate to ensure all fasteners are tightened before operation.

CAUTION: DO NOT START THE TRACTOR UNTIL ALL HOSES ARE ATTACHED, TANK IS FILLED WITH PROPER OIL AND BALL VALVES ARE OPEN! STARTING AT THIS TIME WILL CAUSE SERIOUS DAMAGE TO THE PUMP.

ASSEMBLY

COOLER MOUNTING

Refer to the parts section for location of stand, brackets and hardware. The cooler stand is mounted to the fenders and upper cab, using hardware as shown in the parts section. Unbolt the upper rear cab lights and leave lights hang by the wires, **DO NOT CUT THE WIRES**. Assemble mounting brackets to the cooler stand as shown. Raise the cooler stand into position and reinstall bolts in cab light mounting holes. Fully open and close rear cab window to insure clearance between stand and window. Use the bracket as a template to mark location of holes in fender. Drill 3/8" holes and install stand with the hardware as noted in parts section. Reinstall rear lights to the mounting brackets. Remove the two capscrews from each side of the cooler. Mount the cooler between the brackets on the cooler stand using the pre-existing hardware removed from the cooler. Install fittings and run hoses to locations as noted.

GENERAL HOSE INSTALLATION

Refer to the parts section for detailed information about hoses and fittings for this application.

When mounting the suction hose between the pump and the tank, the stainless steel bands that are provided must be used. CAUTION: DO NOT use regular hose clamps for this purpose.

For protection of hoses in contact with metal edges, wrap hoses with split hose sections and fasten with hose clamps or zip ties as needed.

HOSE COVERING

Secure hoses together with zip ties wherever loose. Wrap the hoses between the main boom and secondary boom with the new hose cover, secure with string provided. Where hoses may contact the frame or other edges, wrap with split hose and secure with hose clamps or zip ties. On non cab units the pressure and return hoses from the control valve will also need to be routed inside the protective clear hose wrap. Cover the valve, valve fittings with the new hose cover and secure with string provided.

ASSEMBLY

MOTOR SOLENOID VALVE MOUNTING

Install a motor solenoid valve to the bracket on main frame with the capscrews, star lockwasher flatwasher, lockwashers and hex nuts as shown in the parts section. Be sure that the pump and tank oil ports are pointing down. Be sure that the star and regular lockwashers are not on the same capscrew. Ground one of the red solenoid wires to the mounting bolts with the star lockwasher at this time.

FILLING HYDRAULIC RESERVOIR

Refer to the maintenance section for filling specifications and hydraulic oil requirements.

NOTE: Starting or running your Tiger mower before filling reservoir will cause serious damage to hydraulic pump.

ADJUSTING REAR WHEELS

Follow the instructions in the tractor owners manual for adjusting tires and rims. The rear wheels MUST be adjusted to the widest setting. NOTE: This may require switching the wheels to opposite sides of the tractor. Also take note of any width restrictions when transporting by trailer. (For ease of installation, it is best to leave rear wheels removed during installation of the mower).

3-POINT DECK TILT CYLINDER

Remove the support cylinder from the left rear three point arm and replace with the cylinder, clevis ends, and pin furnished in the kit. See part section for parts and assembly.

ASSEMBLY

CABLE LIFT DRAFT BEAM INSTALLATION

Install ½" O-ring breather into butt port of inboard cylinder. Install fittings in the rod end of the cylinder according to the diagram in the commons section. These fittings should be positioned to face the butt end of the cylinder.

Next turn the clevis onto the rod of the cylinder until it is tight against the shoulder and lock into place with locking bolt on clevis.

The inboard cylinder can now be installed into the main frame mast with the pin, flat-washers and R-clips as shown below. Use teflon tape on all fitting and hose connections.

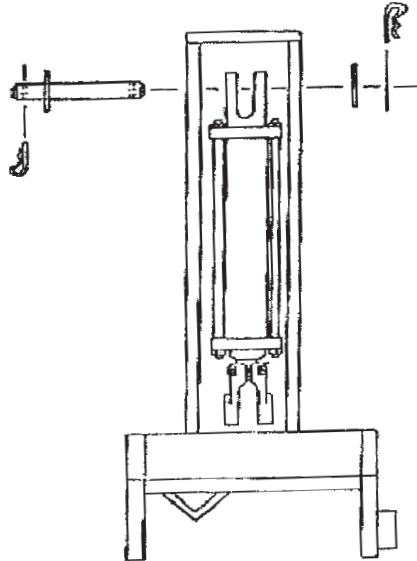

DRAFT BEAM MOUNTING

Pull the inboard cylinder piston rod down to the extreme extended position. Slide the draft beam under the cylinder, and align clevis hole with draft beam hole nearest to the tractor. Install pin and secure with R-clips.

Using inboard cylinder as a pivot point, slide draft beam under tractor and install draft beam pin. Align hole in draft beam pin with holes in main frame boss and install cap-screw, lock-washer and hex nut.

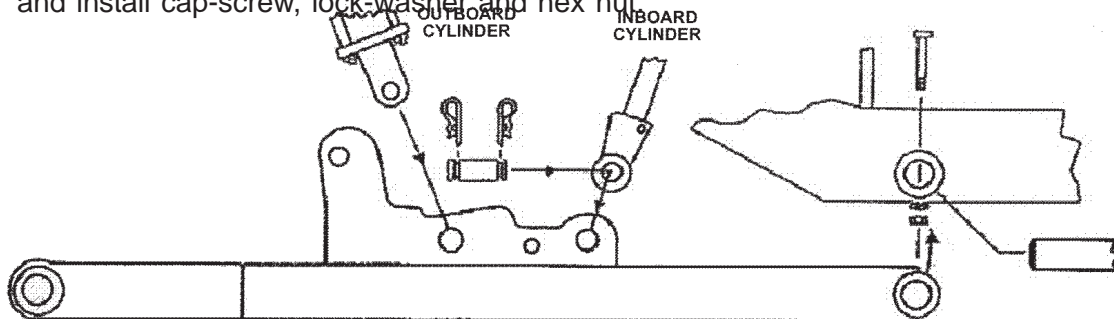

Install the fittings in the butt end of the outboard cylinder, as shown in the commons section. These should be positioned to face the rod end of the cylinder. Next, install the O-ring breather in the rod end of the cylinder.

Install the outboard cylinder in the hole in the draft beam as shown above. Install the pin into the draft beam and cylinder and secure with R-clips.

ASSEMBLY

DECK MOUNTING AND LIFT ASSEMBLY

Install the upper sheave bracket on the outboard cylinder and tighten securely against piston rod shoulder. Tighten the set screw, and align the draft beam.

Install the lower sheave bracket on the draft beam with a $\frac{3}{4}$ " cap-screw and two hex nuts as shown in the diagram on the next page.

Align the deck with the draft beam mounting hole and install the outer draft beam pin. Align the holes in the draft beam pin with the holes in the boss and secure with cap-screw, lock-washer and hex nut.

Pass the lift cable through upper sheave bracket and attach to turn buckle with turn buckle pin and cotter key. Attach turn buckle to draft beam with turn buckle pin and cotter key.

Place the cable in the upper sheave bracket with the cable on top of the wheel. Secure wheel with sheave pin (with grease zerk) and R-clip. Place lift cable in lower sheave below the wheel and install sheave with pin (with grease zerk) and R-clip. Then install the

The cable can now be attached to the deck mounting bracket with the shackle. Tighten shackle pin securely. **NOTE: DO NOT tighten the turn buckle at this time!**

Refer to the commons section for further reference and part numbers.

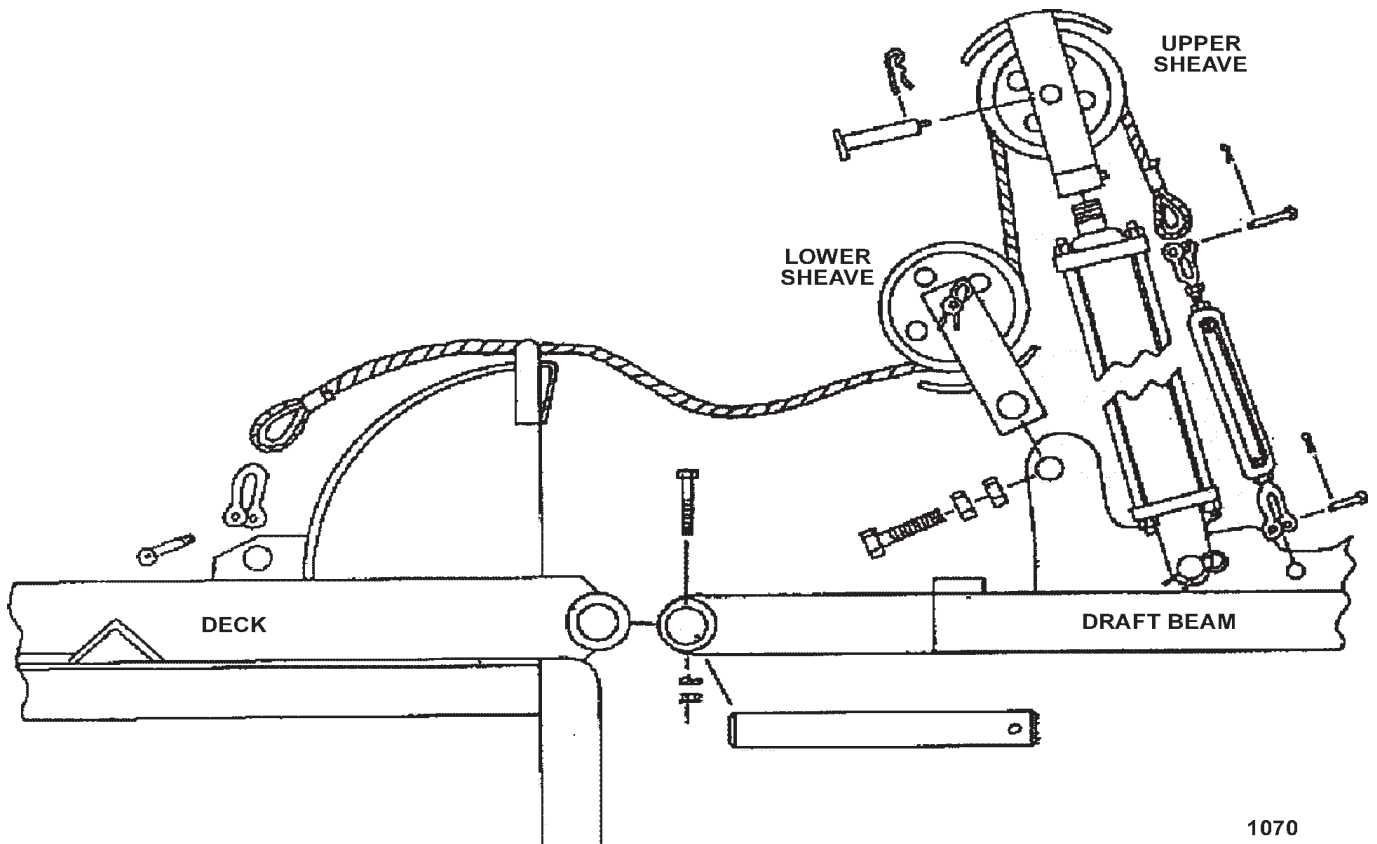

ASSEMBLY

LIFT CONTROL FEEDLINES

Hose lengths will vary between tractor applications such as cab and non-cab units. See the parts section that pertains to your tractor for hose applications.

Install a hose from the bottom or inner valve port (in fender well for cab units, on stand for non-cab units) to the restrictor on the inboard cylinder gland.

Install a hose from the upper or outer valve port to the restrictor on the outboard cylinder butt. Use teflon tape on all fitting and hose connections.

DECK / MOTOR FEEDLINE

Install the hose with the 90 degree #20 flange on one end between the front side of the motor to the bottom of the solenoid valve. Secure to motor with #20 flange kit.

Install the #20 flange adapter block to the back side of the motor and install swivel fittings. Install the hose from the fittings on the back of the motor to the top of the solenoid valve. Install split hoses around hydraulic hoses where they contact the edge of the head, or any other edges that may rub hoses.

Be sure that all grease zerks are installed in the draft beam pin bosses. Grease all areas of the draft beam according to the instructions in the maintenance section.

Re-check all fittings for tightness and be sure teflon tape has been used at all connections.

Fill hydraulic tank with fluid as recommended in the maintenance section. **BE SURE TO OPEN THE BALL VALVES.** Start the tractor and operate the inboard cylinder through the entire stroke and the outboard cylinder through the bottom $\frac{3}{4}$ stroke repeatedly to clear the lines of air. **DO NOT run outboard cylinder out to full stroke until turnbuckle has been adjusted!**

Check for oil leaks at all fittings and connections using a piece of paper or cardboard. **DO NOT USE HANDS TO CHECK FOR FLUID LEAKS!**

Raise the tree point hitch and check the tractor internal hydraulics, fill to proper level if needed.

TURNBUCKLE ADJUSTMENT

Extend the outboard cylinder until the deck touches the stop on the draft beam. Hold the deck in this position to adjust the lift cable tension. Adjust turn buckle until cable is tight.

Lower and raise the deck to check adjustment. The mower deck should reach it's stop on the draft beam at the same time the outboard cylinder reaches it's extreme extended position.

Finally tighten the turn buckle lock nuts securely. It will be necessary to readjust the turn buckle after the cable has stretched from use.

ASSEMBLY

FINAL PREPARATION FOR OPERATION

Place operators safety and operation decals on the steering column and side counsel where they are clearly visible to the operator. These decals should be understood by each operator of the machine in conjunction with the safety and operation section of this book. The decals are to remain in good condition as a reminder to the operator, and should be replaced if damaged.

Double check that all pivot points have been greased. Secure all hoses together with zip ties and wrap with split hose sections where friction may occur on the hose.

WARNING!



BEFORE starting or operating the tractor you must read and understand the safety and operation sections of this manual completely.

Before operating the mower, the cutter head and draft beam should be slowly moved throughout the full range of motion. Watch for any condition that would cause pinching or excess stress on the hoses. The steering and front axle travel should also be carefully moved through their full range of motion. If any condition occurs in which the hoses contact the tires, the steering and / or front axle travel may need to be limited as described in the tractor operators manual. This should also be done if the tires rub, or are extremely close to any other part of the mower such as the hydraulic tank or draft beam. This may include adding shims, or adjusting stop bolts in the tractor front to solve the problem. While checking motion, you should also check that the control circuits are connected according to the operators decal for the valve handles.

MOWER TESTING

Take the tractor to a place free of loose objects on the ground. Operate the cylinders through their full range of motion again, to clear the lines of air. Follow the instructions in the operation section to operate the mower. Vibration of the mower should be minimal at all times. After a 5 minute test run, the knife bolts should be retorqued and once again after the first few hours of operation.

If any parts of this assembly section, or any other section of this manual are not clearly understood you must contact your dealer or the address on the front of this manual for assistance!

ASSEMBLY

COMBO LIFT DRAFT BEAM INSTALLATION

Install ½" O-ring breather into butt port of inboard cylinder. Install fittings in the rod end of the cylinder according to the diagram in the commons section. These fittings should be positioned to face the butt end of the cylinder.

Next turn the clevis onto the rod of the cylinder until it is tight against the shoulder and lock into place with locking bolt on clevis.

The inboard cylinder can now be installed into the main frame mast with the pin, flat-washers and R-clips as shown below. Use teflon tape on all fitting and hose connections.

Install all fittings in the outboard cylinder and adjust to point towards the butt end of the cylinder. Attach the hoses as specified in the parts book. Slide the cylinder into the draft beam from the outside of the draft beam and attach cylinder to the draft beam with clevis pin and rollpins.

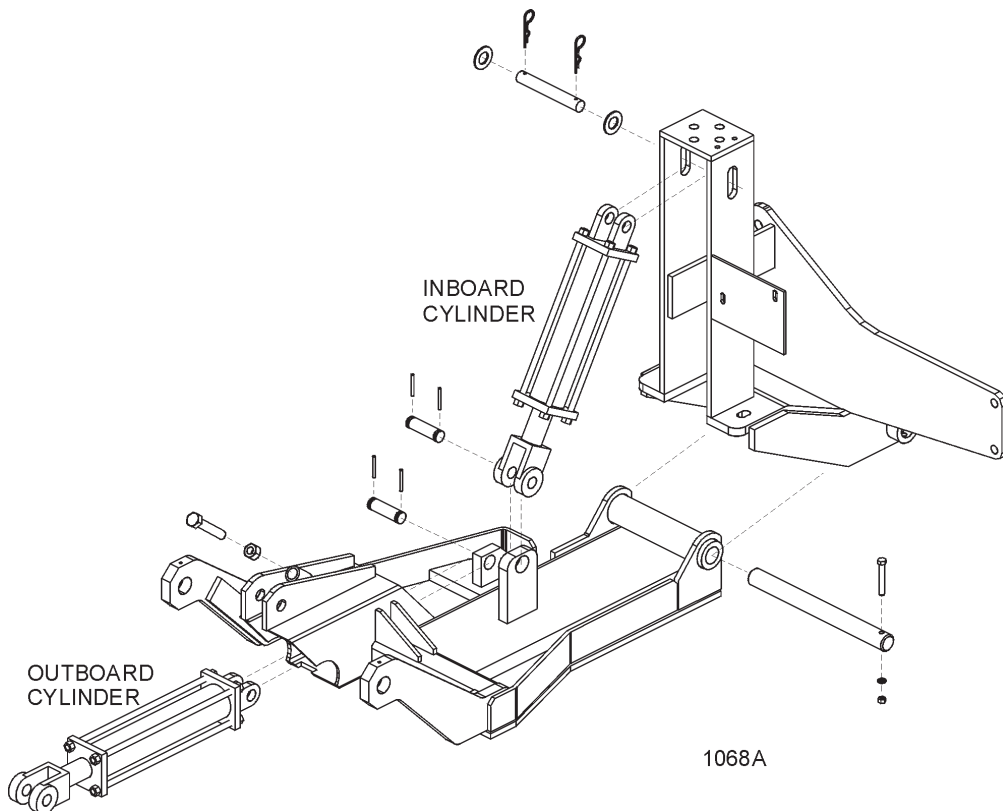

DRAFT BEAM MOUNTING

Pull the inboard cylinder piston rod down to the extreme extended position. Slide the draft beam under the cylinder, and align clevis hole with draft beam hole nearest to the tractor. Install pin and secure with rollpins.

Using inboard cylinder as a pivot point, slide draft beam under tractor and install draft beam pin. Align hole in draft beam pin with holes in main frame boss and install cap-screw, lock-washer and hex nut.

ASSEMBLY

DECK MOUNTING

Check that all grease zerks have been installed in the draft beams pivot arm, left linkage arm, right linkage arm, and cylinder mounting ears.

Using a clevis pin and roll pins, connect the pivot arm to clevis on draft beam.

NOTE: Make sure the longer distance between the cutout and the end of the pivot arm is closest to the draft beam pivot ears on the center tube as shown in the diagram below. Also make sure the cutout on the pivot arm faces into tube of draft beam.

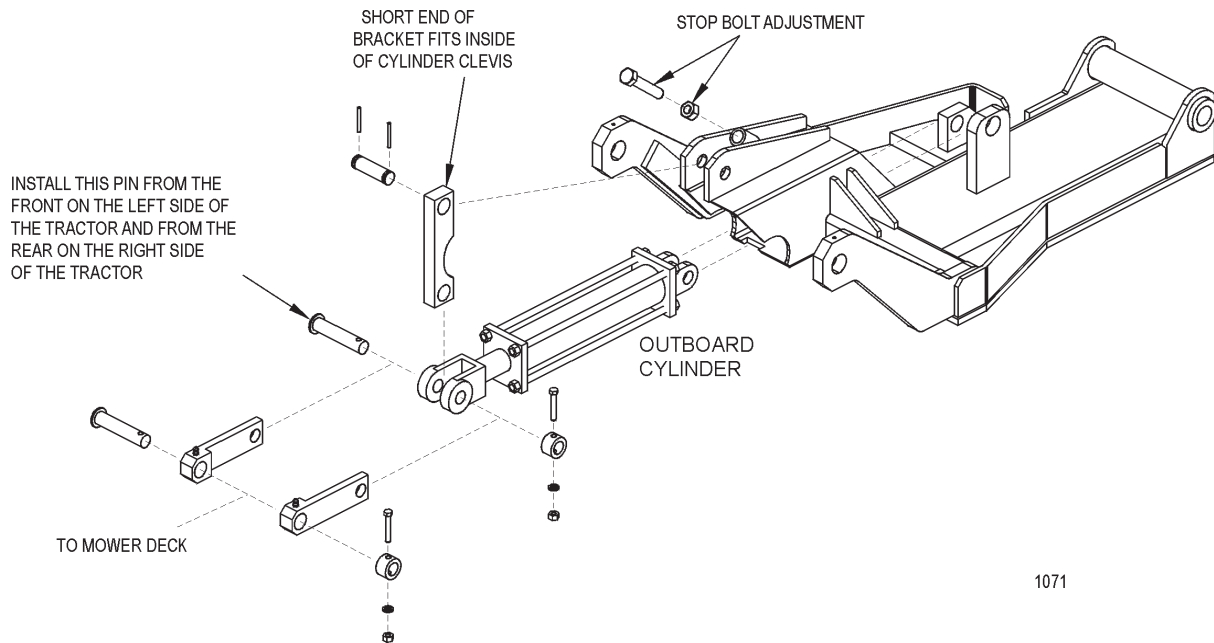

1071

Slide other end of pivot arm with short distance between the cut-out and the end of the pivot arm, into the cylinder clevis. Next, line up the holes of the left and right lift linkage arms outside of the cylinder clevis holes. Connect with linkage pin, shims (as required), boss, cap-screw, lock-washer and hex nut as shown.

To connect the bonnet to the draft beam, slide the extension arms of the draft beam between the mounting ears on the inner end of the bonnet. Line up the holes and secure with swivel pin, cap-screw, lock-washer, and hex nut (both sides). See parts book illustration.

Next, slide the left and right linkage arms up to the slotted ear on the side of the deck. Secure with linkage pin, shims, boss, cap-screw, lock-washer and hex nut. See illustration in parts section.

LIFT CONTROL FEEDLINES

Hose lengths will vary between tractor applications such as cab and non-cab units. See the parts section that pertains to your tractor for hose applications.

Install a hose from the bottom or inner valve port (in fender well for cab units, on stand for non-cab units) to the restrictor on the inboard cylinder gland.

Install a hose from the upper or outer valve port to the restrictor on the outboard cylinder butt. Use teflon tape on all fitting and hose connections.

ASSEMBLY

DECK / MOTOR FEEDLINE

Install the 1" hose with the 90 degree flange on the front side of the motor to the inside upper oil port of the solenoid valve. Secure to motor with flange kit, and install swivel fittings on the other end. Install the other 1" hose with the 60 degree flange on the back side of the motor to the inside lower oil port of the solenoid valve.

Install split hoses around hydraulic hoses where they contact sharp edges, or any other edges that may rub hoses.

Be sure that all grease zerks are installed in the draft beam pin bosses. Grease all areas of the draft beam according to the instructions in the maintenance section. Re-check all fittings for tightness and be sure teflon tape has been used at all connections.

Fill hydraulic tank with fluid as recommended in the maintenance section. **BE SURE TO OPEN THE BALL VALVES.** Start the tractor and operate the inboard cylinder through the entire stroke and the outboard cylinder through the bottom $\frac{3}{4}$ stroke repeatedly to clear the lines of air. **DO NOT run outboard cylinder out to full stroke until stop bolt has been adjusted!**

Check for oil leaks at all fittings and connections using a piece of paper or cardboard. If a leak is found, you must shut down the tractor and set the cutter head on the ground. Before attempting to fix the leak, you must actuate the lift valve handles several times to relieve any pressure in the lines. **DO NOT USE HANDS TO CHECK FOR FLUID LEAKS!**

Raise the three point hitch and check the tractor internal hydraulics, fill to proper level if needed.

STOP BOLT ADJUSTMENT

Extend the outboard cylinder all the way out. Adjust the stop adjustment bolt (located on the top of the draft beam) out until it is up against the bonnet. Lock the bolt down with the $\frac{3}{4}$ " hex nut.

NOTE: When the outboard cylinder is fully extended, the bonnet or deck should either be up against the stop or if travel locks are installed, it should be up against the travel lock. It may be necessary to use either external or internal slugs on the cylinder to get the correct stroke. If the cutter head is against the stop and the cylinder has stroke remaining, serious damage will occur.

Proceed to final preparation for operation instructions on the next page.

ASSEMBLY

Mount the solenoid switch, drill holes to match, and 30 AMP breaker mounting tab, mount in dry and well protected area. Secure with 3/8" x 1" capscrews, lockwashers, and hex nuts.

A.) RED 6 GA. wire from terminal (D) to +12 volt battery post on starter solenoid.

B.) RED 14 GA. wire from terminal (C) to +12 terminal on fuel pump.

C.) GREEN 14 GA. wire from terminal (B) to negative ground.

D.) RED 8 GA. wire from terminal (A) to 30 AMP breaker.

E.) RED 14 GA. wire from terminal (A) to double switch box.

F.) RED 14 GA. wire from terminal (A) to temperature gauge. (optional)

G.) RED 8 GA. wire from breaker to reverser switch terminal (2).

H.) RED 8 GA. wire from terminal (1) to +12 volt terminal on cooler fan.

I.) BLACK 8 GA. wire from terminal (3) to ground on cooler fan.

J.) BLACK 8 GA. wire from terminal (4) to control panel ground.

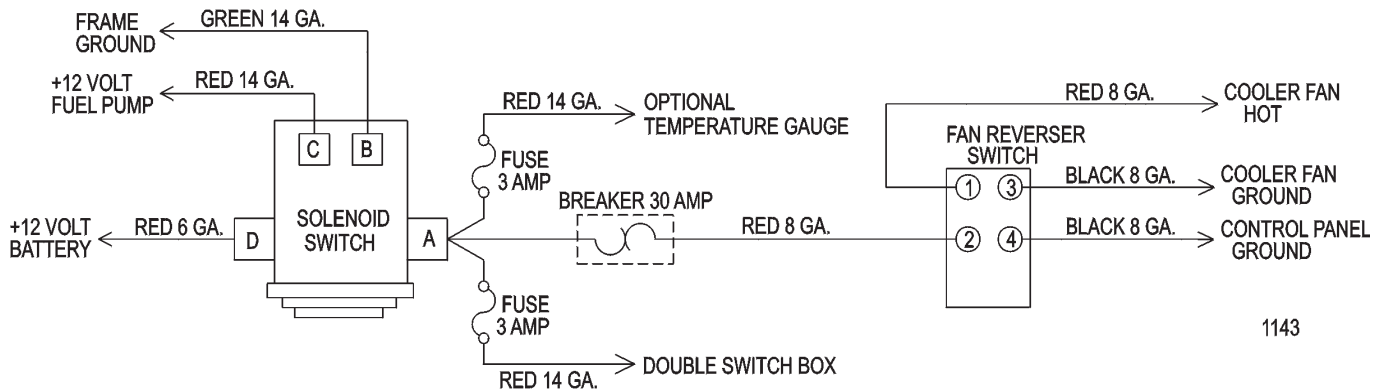

1143

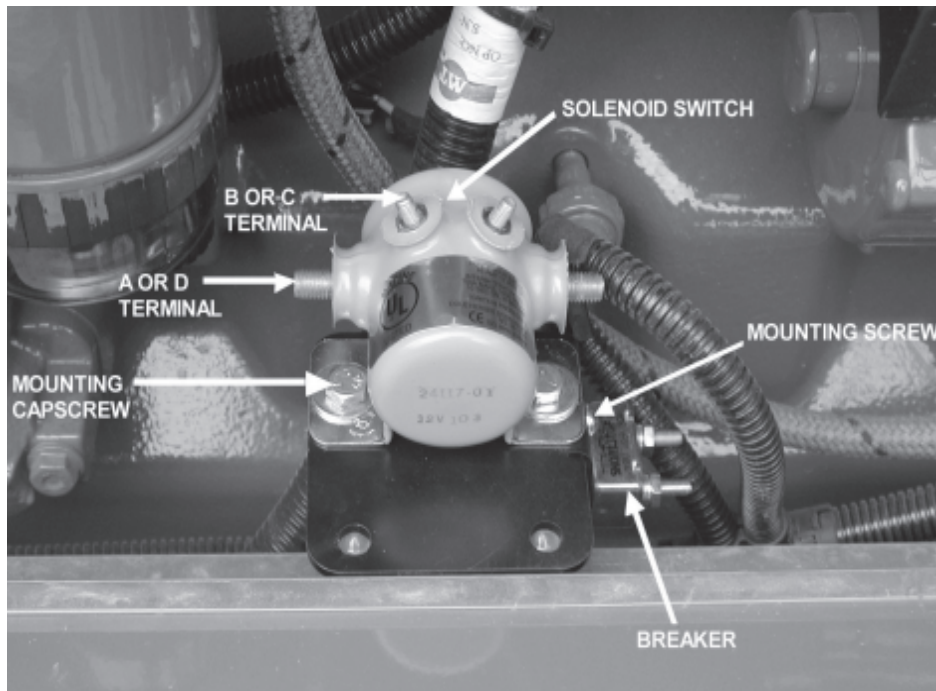

ASSEMBLY

FINAL PREPARATION FOR OPERATION

Place operators safety and operation decals on the steering column and side counsel where they are clearly visible to the operator. These decals should be understood by each operator of the machine in conjunction with the safety and operation section of this book. The decals are to be maintained in good condition as a reminder to the operator, and should be replaced if damaged.

Finally, all bosses, pins and pivot points will need to be greased as instructed in the maintenance section of this manual. The hydraulic reservoir can also be filled with the recommended fluid (see maintenance section) and the filter installed in the top of the tank. Double check all fittings and fasteners **BEFORE** starting tractor. Also secure any loose hoses together with zip ties and wrap with split hoses where friction may occur on the hoses.

WARNING!



BEFORE starting or operating the tractor you must read and understand the safety and operation sections of this manual completely.

BE SURE THE BALL VALVES ARE OPEN! Start tractor and allow instruments to stabilize. Using a piece of paper or cardboard as noted in the safety and maintenance sections, check all fittings and connections for hydraulic leaks.

If a leak is found, you must shut down the tractor, set the cutter on the ground. Before attempting to fix the leak, you must actuate the lift valve handles several times to relieve any pressure in the lines.

Before operating the mower, the cutter head and boom should be slowly moved throughout the full range of motion. Watch for any condition that would cause pinching or excess stress on the hoses. The steering and front axle travel should also be carefully moved through their full range of motion. If any condition occurs in which the hoses contact the tires, the steering and / or front axle travel may need to be limited as described in the tractor operators manual. This should also be done if the tires rub, or are extremely close to any other part of the mower such as the hydraulic tank or draft beam. This may include adding shims, or adjusting stop bolts in the tractor front to solve the problem. While checking motion, you should also check that the control circuits are connected according to the operators decal for the valve handles.

MOWER TESTING

Take the tractor to a place free of loose objects on the ground. Operate the cylinders through their full range of motion again, to clear the lines of air. Follow the instructions in the operation section to operate the mower. Vibration of the mower should be minimal at all times. After a 5 minute test run, the knife bolts should be retorqued and once again after the first few hours of operation.

If any parts of this assembly section, or any other section of this manual are not clearly understood you must contact your dealer or the address on the front of this manual for assistance!

OPERATION SECTION

OPERATION

Safety is of primary importance to the owner / operator and to the manufacturer. The first section of this manual includes a list of Safety Messages, that, if followed, will help protect the operator and bystanders from injury or death. Many of the messages will be repeated throughout the manual. The owner / operator / dealer should know these Safety Messages before assembly and be aware of the hazards of operating this mower during assembly, use, and maintenance.

The **Safety Alert Symbol** combined with a signal word, as seen below, is intended to warn the owner / operator of impending hazards and the degree of injury possible during operation.

DANGER!



Indicates an imminently hazardous situation that, if not avoided, WILL result in DEATH OR VERY SERIOUS INJURY.

WARNING!



Indicates an imminently hazardous situation that, if not avoided, COULD result in DEATH OR SERIOUS INJURY.

CAUTION!



Indicates an imminently hazardous situation that, if not avoided, MAY result in MINOR INJURY.

IMPORTANT!

Identifies special instructions or procedures that, if not strictly observed, could result in damage to, or destruction of the machine, attachments or the environment.

NOTE: *Identifies points of particular interest for more efficient or convenient operation or repair.* (SG-1)

CAUTION!



Before any operation of tractor and mower, the user should read and understand the safety and operating instructions for both the tractor and the mower. The user should also be familiar with the location and functions of the units instruments and controls. Being familiar with the machine and its controls will increase efficiency and reduce possibility of serious injury or damage to the unit. The operator should work slowly and carefully until he feels comfortable with the machine. Speed and skill will be attained much easier if the necessary time is spent to familiarize yourself with the machine and its operations.

Since tractor makes and models vary, we recommend reading and following the operators manual provided by the manufacturer pertaining to your particular unit.

OPERATION



STARTING TRACTOR AND MOWER



Check the operators manual received from the tractor manufacturer, for their recommendation and procedures pertaining to your particular make and model.

WARNING!



When rotating parts are in motion, serious injury may occur if caution is not used or danger is not recognized. Never allow bystanders within **300 feet** of the machine when mower is in operation.



Be sure the ball valves on the mower hydraulic tank are **OPEN** before starting the tractor. Serious damage to the hydraulic system can occur if the valves are not open.

WARNING!



Check to make sure mower switch is in the “**OFF**” position. The unit is designed not to start if the switch is in the “on” position. If tractor starts with switch on, turn off tractor and contact your local Tiger dealership for assistance.

Start the tractor and allow the instruments to stabilize. Without starting the mower, practice positioning the boom and deck. Remember, speed and skill will be attained easier if the necessary time is spent familiarizing yourself with the machine and its operations. When you feel comfortable at controlling the position of the mower, return the mower to the travel position, and transport the mower to the desired mowing location.

If mowing for the first time with a Tiger Boom Mower, we recommend choosing a ditch or area relatively flat with a minimum of sign posts, guard rails, etc. As always, you should inspect the area for other objects that can cause potential hazards.

The Mower Control switch turns the mower “ON” and “OFF”. This switch is to be in the “OFF” position to start the tractor. The tractor will not start with the switch in the “ON” position.

WARNING!



If tractor starts with switch on, turn off tractor and contact your local Tiger dealership for assistance.

OPERATION

CONTROL LOCATION AND FUNCTIONS

The side mower height is controlled with a two or three spool valve and is coordinated as shown below. The optional three spool valve allows for the operation of a rear rotary mower or side ditcher. If the unit is equipped with a three spool valve, do not operate the third spool handle unless a rear rotary or ditcher is mounted.

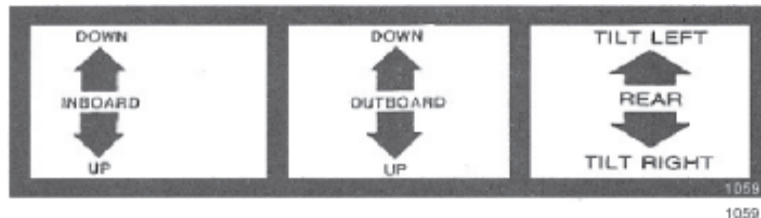

The rear mower height is controlled with the 3-point hitch control lever. Follow the instructions for this control in the tractor operators manual. The tilt of the rear mower is controlled with the third spool if the lift valve and is coordinated as shown above.

The side and rear mower positions may optionally be controlled with the tractor's remote hydraulic connections or a combination of lift valve and remote hydraulics. If so, determine which position of the side or rear mower is to be controlled by each remote lever.

The side mower ON / OFF switch is located in a switch box mounted to the valve stand or cable controls for non-cab and cab units respectively. If operating a rear mower, the ON / OFF switch is located in the switch box with a side mower switch.

This machine may be equipped with an auxiliary oil temperature gauge, an amp gauge or oil pressure gauge. If oil temperature reaches 200 degrees Fahrenheit, stop mowers and see trouble shooting section for possible causes. Keep an eye on all gauges for indication of problems.

MOWER OPERATION

WARNING!



When rotating parts are in motion, serious injury may occur if caution is not used or danger is not recognized. Never allow bystanders within **300 feet** of the machine when in operation. Extreme care should be taken when operating near loose objects – such as gravel, rocks and debris. These conditions should be avoided.

The rotating parts in this machine have been designed and tested for rugged use. However, they could fail upon impact with heavy solid objects – such as steel guard rails, concrete abutments, etc., causing them to be thrown at a very high velocity. Never allow cutter head to contact such objects. Inspecting the cutting area for such objects prior to mowing can help eliminate these potential hazards.

OPERATION

Once on location, lower the mower deck slightly above the material to be cut, so the mower does not have to start under a load. Bring the R.P.M. of the tractor up to 1200 and engage the side mower. If a rear mower is being used, allow the R.P.M. to return to 1200 before engaging the rear mower.

The rotary mower deck should always be carried rather than dragged on the skid shoes when mowing on the ground. Dragging the rotary mower heads causes an extreme side load on the tractor resulting in premature tire wear. It also causes excessive horsepower consumption and drastically decreases blade life. Dragging the rear mower can also cause damage to the road. Once the necessary skill is attained at controlling the height and position of the side rotary mower, it will be easy to carry the mower head(s) and do a proficient job of cutting.

When cutting tall shrubs or small trees (maximum recommended size of material to be cut is 2" diameter) begin each pass at the top of the material and work down with each consecutive pass. Use a low speed to allow the cutting blades time to mulch as well as cut the foliage. When the initial pass has been made, disengage the mower and return the mower to the travel position. Return to the starting point and make next pass, etc.

CAUTION!



When using the rotary cutting head for trimming trees and shrubs, let the mower saw into them. Do not lower the mower head down directly onto a tree or stump. The mower blades are designed to cut with the end, and misuse can cause damage to the blade and a hazardous situation for the operator.

To ensure a clean cut, engine speed should be maintained at approximately 1800 – 2200 R.P.M. If the tractor slows to less than 1800 R.P.M., shift to the next lower gear. **DO NOT** ride the clutch, this will cause premature clutch failure. **The engine should not be operated at any time at more than 2400 R.P.M. on the tractor tachometer.**

DO NOT use excessive force when positioning cutting head into heavy branches or small stumps (2" diameter). Damage to the unit may result. It is best to let the cutter head "eat away" slowly at heavy cutting jobs.

The mower will operate more efficiently in tougher conditions and with less power if the knives are kept sharp. If the mower begins to vibrate, stop the tractor, check for wire wrapped in the spindle or damaged knives. When replacing knives, replace all knives with new knives to ensure proper balance so the mower will not vibrate. Severe vibration will result, if knives with unequal wear are used. Follow the instructions in the maintenance section closely when replacing knife blades.

WARNING!



If bystanders approach within 300 feet while mower is in operation turn mower switch "OFF" immediately! After shutdown, never leave the tractor or allow bystanders to approach within **300 FEET** of the unit until all motion stops completely.

OPERATION

When encountering a very severe condition which causes the tractor to stall, disengage mower, start tractor, raise the mower from the cut. Shut tractor off and inspect the mower, blades and disk for damage before engaging mower again.

If the blades jam or stop, disengage the clutch and raise the head slightly or back the tractor up. Normally, this will clear the cutter head. If not, shut off the mower(s), raise the cutter heads, turn off the tractor and set the parking brake. After all motion stops completely, leave the tractor and clear the cutting heads manually.

After the first day of operation, all bolts should be checked and tightened securely. This should be done periodically to ensure the bolts do not become loose and cause damage to the tractor or mower, or injury to the operator.

REVERSE FAN OPERATION

Normal operation - Operating position is with fan switch ON (upper position)

Reversing fan to clear chaff -Reverser fan switch is to be used as follows as necessary for clearing chaff from cooling fins:

1. Normal operating position is with fan switch ON (upper position)
2. Turn fan switch OFF (center position), wait at least 3 seconds
3. Push switch DOWN to reverse,
4. Allow chaff to clear
5. Turn fan switch OFF (center position), wait at least 3 seconds
6. Turn fan switch to ON (upper position)

OPERATION

TRANSPORTING MOWER

Transporting under the units own power:

When transporting between job sites or between cutting passes, the following procedure should be followed: Shut off the power to the cutting head(s) and allow all motion to come to a complete stop. Raise the draft beam to it's highest position. Raise the side mower until the deck stops against the draft beam. Raise the rear mower with the 3-point hitch control lever. The unit is now in position for self transportation.

Transporting unit by flatbed trailer:

Most tractors with a side mounted mower head attached will be over legal transporting width (102" wide). For this reason, one of the following procedures must be followed.

1: Transporting with side mower attached: Use a loading dock or ramp to load tractor onto the trailer. Center the tractor with the mowers attached between the sides of the trailer. Make sure the draft beam and head are fully raised and secured. Lower the rear mower onto the trailer. Secure the tractor and rear mower to the trailer with chains. Obtain proper over-width permits and mark the vehicle and mower as over-width as required be law. Check the tractor operators manual for any tractor requirements to transport by flatbed trailer.

2: Transporting with side mower removed: Park the tractor and turn the engine off. Remove the key to avoid accidental starting. Close ball valves on the hydraulic reservoir. To avoid contaminating the hydraulic system, make sure all fittings on the side mower motor and solenoid control valve are clean. Disconnect the motor pressure hose at the solenoid valve and the motor return hose at the motor. See diagram below.

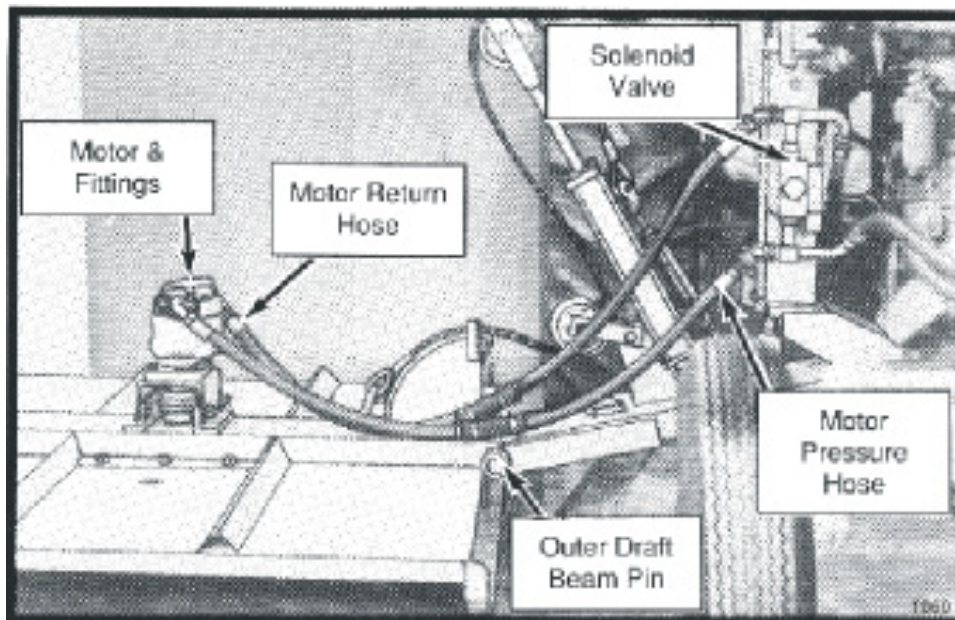

OPERATION

Next, switch the hose ends and reconnect to form two separate closed loops, see diagram below. Disconnect the lift cable from the head and secure the loose end back onto the cable with the cable clevis. Remove the keeper bolt and draft beam outer pivot pin. Separate the mower head from the tractor. Now reinstall the pivot pin and keeper bolts into the draft beam to prevent loss. **OPEN THE BALL VALVES ON THE HYDRAULIC RESERVOIR BEFORE STARTING TRACTOR AGAIN!** Serious damage will be caused if tractor is started with the ball valves closed.

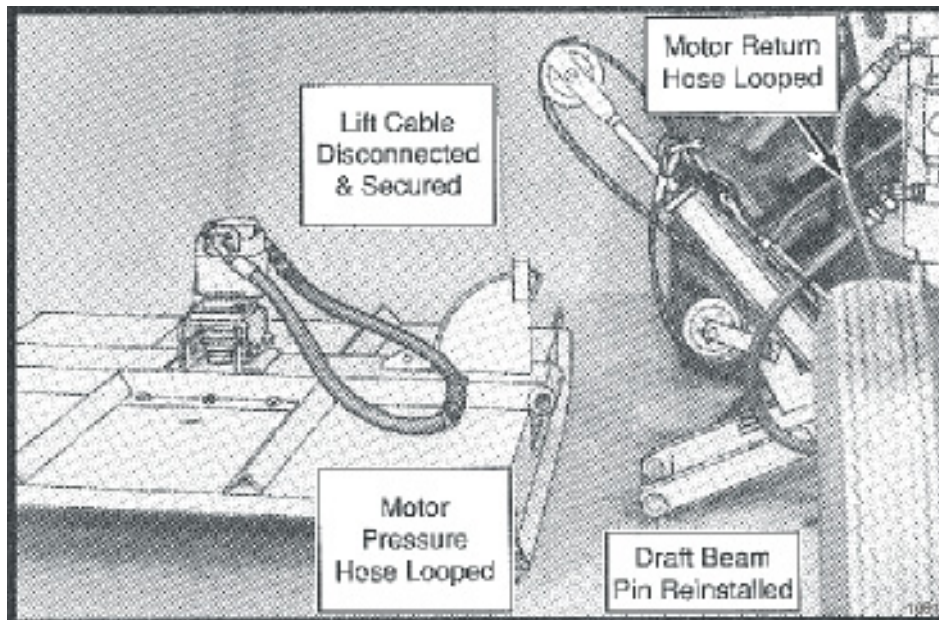

Use a loading dock or ramps to load the tractor onto the trailer, centering the tractor between the sides of the trailer. Make sure the tractor (and rear mower) and trailer are within legal transporting width. Lower the rear mower onto the trailer and set the loose hide mower on the trailer. Secure the tractor and mowers to the trailer with chains. Check the tractor operators manual for any requirements to transport be flatbed trailer. Reverse this procedure to unload and remount the mowers after transporting. Be sure all pins are secure, all connections are tight and any lost fluid is replaced before using mowers. Use teflon tape when connecting all fittings.

CAUTION!



If any part of this operating section, or any other section of this manual is not completely understood, contact your Tiger dealer or the address on the cover of this manual for assistance!

OPERATION

INSPECTION SHEETS

OPERATION

Rotary Mower PRE-OPERATION Inspection



Tractor ID# _____ Make _____

Date: _____ Shift _____

WARNING!



Before conducting the inspection, make sure the Tractor engine is off, all rotation has stop and the tractor is in the Park with the parking brake engaged. The Mower head is resting on the ground (or is securely blocked up and supported) and all hydraulic pressure has been relieved.

Item	Condition at Start of Shift	Specific Comments if not O.K.
The Operator's Manual is in the Canister on the mower		
All Safety Decals are in place and legible		
The Mounting frame bolts are in place and tight		
There are no cracks in Draftbeam or Yolk		
The Draftbeam/Yolk connection bolts & pins are tight		
There are no cracks or holes in mower deck		
The Hydraulic motor mounting bolts are tight		
The mower head spindle housing is tight and lubricated		
There mower deck is clear of cut grass and debris		
The Skid shoes are in good condition & tight		
Chain Guards/Deflectors are in place & in good condition		
Blade carrier retaining nut is tight		
Blades are not chipped, cracked or bent		
Blade bolts are tight		
Transport locks are in good condition		
There are no leaking or damaged hoses		
There is no evidence of Hydraulic leaks		
The Hydraulic Oil level is full		
The Hydraulic Cylinders pins are tight		
The Hydraulic Pump hose connections are tight		
The Hydraulic Valve hose connections are tight		
The Hydraulic Valve controls function properly		
Wheel lug nuts are tight		

Operators Signature: _____

DO NOT OPERATE an UNSAFE TRACTOR or MOWER

OPERATION

TRACTOR PRE-OPERATION Inspection



Tractor ID# _____ Make _____

Date: _____ Shift _____

WARNING!



Before conducting the inspection, make sure the Tractor engine is off, all rotation has stop and the tractor is in the Park with the parking brake engaged. The Mower head is resting on the ground (or is securely blocked up and supported) and all hydraulic pressure has been relieved.

Item	Condition at Start of Shift	Specific Comments if not O.K.
The Flashing lights function properly		
The SMV Sign is clean and visible		
The Tires are in good condition with proper pressure		
The Wheel Lug bolts are tight		
The tractor Brakes are in good condition		
The Steering linkage is in good condition		
There are no visible Oil Leaks		
The Hydraulic controls function properly		
The ROPS or ROPS Cab is in good condition		
The Seatbelt is in place and in good condition		
The 3-Point Hitch is in good condition		
The Drawbar pins are securely in place		
The PTO Master Shield is in place		
The Engine Oil level is full		
The Brake Fluid level is full		
The Power Steering Fluid Level is full		
The Fuel level is adequate		
The Engine Coolant Fluid level is full		
The Radiator is free of debris		
The Air filter is in good condition		

Operators Signature: _____

DO NOT OPERATE an UNSAFE TRACTOR or MOWER

OPERATION

FRONT END LOADER PRE-OPERATION Inspection



Mower ID# _____ Make _____

Date: _____ Shift _____

WARNING!



Before conducting the inspection, make sure the Tractor engine is off, all rotation has stop and the tractor is in the Park with the parking brake engaged. The Loader is resting on the ground (or is securely blocked up and supported) and all hydraulic pressure has been relieved.

Item	Condition at Start of Shift	Specific Comments if not O.K.
The Operator's Manual is in the Canister on the mower		
All Safety Decals are in place and legible		
The Mounting frame bolts are in place and tight		
There are no cracks in Draftbeam or Yolk		
The Draftbeam/Yolk connection bolts & pins are tight		
There are no cracks or holes in mower deck		
The Hydraulic motor mounting bolts are tight		
The mower head spindle housing is tight and lubricated		
There mower deck is clear of cut grass and debris		
The Skid shoes are in good condition & tight		
Chain Guards/Deflectors are in place & in good condition		
Blade carrier retaining nut is tight		
Blades are not chipped, cracked or bent		
Blade bolts are tight		
Transport locks are in good condition		
There are no leaking or damaged hoses		
There is no evidence of Hydraulic leaks		
The Hydraulic Oil level is full		
The Hydraulic Cylinders pins are tight		
The Hydraulic Pump hose connections are tight		
The Hydraulic Valve hose connections are tight		
The Hydraulic Valve controls function properly		
Wheel lug nuts are tight		

Operators Signature: _____

DO NOT OPERATE an UNSAFE TRACTOR or FRONT END LOADER

OPERATION

TRACTOR PRE-OPERATION Inspection



Tractor ID# _____ Make _____

Date: _____ Shift _____

WARNING!



Before conducting the inspection, make sure the Tractor engine is off, all rotation has stop and the tractor is in the Park with the parking brake engaged. The Loader is resting on the ground (or is securely blocked up and supported) and all hydraulic pressure has been relieved.

Item	Condition at Start of Shift	Specific Comments if not O.K.
The Flashing lights function properly		
The SMV Sign is clean and visible		
The Tires are in good condition with proper pressure		
The Wheel Lug bolts are tight		
The Tractor Brakes are in good condition		
The Steering linkage is in good condition		
There are no visible Oil Leaks		
The Hydraulic controls function properly		
The ROPS or ROPS Cab is in good condition		
The Seatbelt is in place and in good condition		
The PTO Master Shield is in place		
The Engine Oil level is full		
The Brake Fluid level is full		
The Power Steering Fluid Level is full		
The Fuel level is adequate		
The Engine Coolant Fluid level is full		
The Radiator is free of debris		
The Air filter is in good condition		

Operators Signature: _____

**DO NOT OPERATE an UNSAFE TRACTOR or FRONT END
LOADER**

OPERATION

MAINTENANCE SECTION

MAINTENANCE

Tiger Mowers are designed for high performance and rugged durability, yet with simplified maintenance. The purpose of this section of the manual is to help the operator in the regular servicing of the mower. Regular maintenance at the intervals mentioned will result in the maximum efficiency and long life of the Tiger Mower.

When you purchase a Tiger Mower you also acquire another valuable asset, Tiger's parts organization. Our rapid and efficient service has guaranteed the customer satisfaction for many years. Tiger parts keep up with the demands for efficiency, safety and endurance expected of the Tiger Mower.

MAINTENANCE PRECAUTIONS

Be sure end of grease gun and zerks are clean before using. Debris injected into bearings, etc. with grease will cause immediate damage.

- DO NOT use a power grease gun to lubricate bearings. These require very small and exact amounts of lubrication. Refer to the detailed maintenance section for specific lubrication instructions. Do Not over-grease bearings.
- Lexan windows should be washed with mild soap or detergent and luke warm water, using a soft clean sponge or **soft cloth**. DO NOT use abrasive or alkaline cleaners or metal scrapers on lexan windows!
- Be alert to maintenance indicators such as the in-tank filter pressure gauge, hydraulic reservoir sight gauge, etc. Take the required action to correct any problems immediately.
- Release of energy from pressurized systems may cause inadvertent actuation of cylinders, or sudden release of compressed springs. Before disconnecting any hoses relieve pressure by shutting tractor off, setting cutter on ground and actuating lift valve handles.

WARNING!



DO NOT use hands to check for suspected leaks in hydraulic hoses! Hydraulic fluid escaping under pressure can have sufficient force to penetrate skin and cause serious injury. If fluid is injected into skin, it must be surgically removed within a few hours or gangrene may result. Use a small piece of wood or cardboard, not hands, to search for pin hose leaks. Be sure all pressure is relieved whenever disconnecting lines. Be sure all connections are tight and hoses and lines are not damaged before applying pressure.

BREAK IN PERIOD

In addition to following the break in instructions for your particular tractor, the in-tank hydraulic fluid filter should be replaced after the first 50 hours of service. Thereafter the filter should be replaced every 500 hours, or yearly, whichever comes first.

Re-torque wheel lugs after first five hours of operation and periodically thereafter. See torque specifications listed in the tractor's service manual for your particular model. **Wheel lugs must always be re-torqued whenever a wheel is removed and reinstalled.**

MAINTENANCE

REGULAR MAINTENANCE

The intervals at which regular servicing should be done are based on hours of operation. Use the tractors hour meter to determine when regular servicing is required.



This symbol indicates a point that needs to be greased at an interval noted in the section below. Refer to the Detailed Maintenance section for further instructions on greasing. Copy and use the Daily Maintenance sheet located at the end of this section.

DAILY OR EVERY 8 HOURS

ITEM	SERVICE	COMMENTS
Drive Shaft Yoke, U-Joint & Stub Shaft	Grease	Grease as instructed in detailed maint. section
Pump Drive Shaft Coupler	Check and Lube	Insure drive shaft end play
Crankshaft Adapter	Check rubber grommets	Replace grommets if damaged or missing
Pivot Points	Lubricate	Inject grease until it appears at ends
Hydraulic Fittings	Check for leaks	Tighten when needed. Do Not use hands to check for leaks, see maint. Precautions
Knives	Check	Inspect for missing or damaged knives, change or sharpen as needed
Spindle mounting bolts (spindle to deck)	Check	3/4" x 2" torque to 331 ft. lbs.
Knife mounting bolts (knife to disk)	Check	Pre-lubricate threads, then torque to 800 ft. lbs.
Disk mounting bolts (disk to spindle)	Check	5/8" x 1-3/4" bolt torque to 204 dry or 184 oiled ft. lbs.
Belts	Check / Adjust	Check if broken, tighten as required
Main Frame and Deck	Check	Retorque bolts to torque specifications in this section
Hydraulic Fluid Level	Check	Add if required per fluid recommendations

MAINTENANCE

WEEKLY OR EVERY 50 HOURS

ITEM	SERVICE	COMMENTS
In Tank Hyd. Fluid Filter (10 micron filter)	Change	Change after first 50 hours only, then every 500 hours or yearly
In-Line High Pressure Filter (10 micron filter)	Change	Change after first 50 hours only, then every 500 hours or yearly

MONTHLY OR EVERY 150 HOURS

Hydraulic Fluid Level	Check	Add as needed
Hyd. Tank Breather	Clean / Check / Replace	Clean or replace Element as required
Rear Tire Type	Max P.S.I.	
480/80R38	29	
18.4-34	26	
18.4-38	26	

YEARLY OR EVERY 500 HOURS

Spindle Grease	Change	
Motor to Spindle Spline	Change	
Hyd. Tank Fluid	Change	
In Tank Hyd. Fluid Filter (10 micron filter)	Change	
In-Line HP Filter (10 micron filter)	Change	or Change when indicated by restriction indicator.
Hyd. Tank Breather	Change	

TROUBLESHOOTING

SYMPTOMS	CAUSE	REMEDY
Vibration	1. Loose bolts 2. Cutter assembly Unbalanced	1. Check all bolts and tighten to torque specs. in this section. 2a. Check for damaged blades, disc. or cutter shaft. Replace if needed. 2b. Check for wire, rope, etc. entangled in cutter assembly
Mower will not lift	1. Hyd. Fluid low 2. Leaks in line 3. Faulty relief valve 4. Kinked / blocked 5. Faulty cylinder	1. Check and refill Hyd. Fluid. 2. Tighten or replace fittings and hoses 3. Check pressure in line. Line pressure in Control Valve should be at least 2500 P.S.I. 4. Clean or replace lines 5. Inspect, repair or replace cylinder

MAINTENANCE

SYMPTOMS	CAUSE	REMEDY
Oil Temperature rises above 200 deg. F	<ol style="list-style-type: none"> 1. Low oil level 2. Kinked or blocked hoses 3. Worn pump/motor 	<ol style="list-style-type: none"> 1. Bring oil to proper level 2. Inspect, Repair, or Replace 3. Disable and repair
Mower will not start or run	<ol style="list-style-type: none"> 1. Blown fuse 2. Ball valves closed 3. Low oil level 4. Line leak 5. Electronic solenoid faulty 	<ol style="list-style-type: none"> 1. Check fuse between mower switch and ignition / replace 2. Make sure valves are open 3. Check Hyd. tank and fill 4. Check all fittings and lines. 5a. Without the tractor running, turn the mower switch to on. A low audible click should be heard if the solenoid is engaging the solenoid spool. If click is not heard, leave switch in on position and with a screwdriver or other steel object, touch the small nut on the end of the solenoid. If the metallic object is not attracted to the nut, check the fuse and wiring for an open circuit. If the object is attracted but no "click" is heard, replace the solenoid. 5b. Remove the four bolts holding the small block to the main block. Lift and remove small block being careful not to damage O-rings / filter. Clean filter and re-install. 5c. Remove large nut on side of large valve block. Remove spring, and use needle nose vise grip to pull spool from block. Check block and spool for contaminates and scratches. Clean parts or replace if scratched.
Motor runs but	<ol style="list-style-type: none"> 1. Belts 2. Tensioner 	<ol style="list-style-type: none"> 1. Inspect belts and pulleys. Replace belts and repair as needed. 2. Adjust tensioner nut until flat washer is flush with top of guide.
Motor turns slowly or not at all.	<ol style="list-style-type: none"> 1. Contaminants restricting spool 2. Suction lines 3. Low oil level 	<ol style="list-style-type: none"> 1. Remove large nut on side of large valve block. Remove spring, and use movement in needle nose vise grip to pull spool valve body from block. Check block and spool for contaminates and scratches. Clean parts or replace if scratched. 2. Check for kinkes or obstruction in obstructed suction hose 3. Check Hyd. tank level and fill
Pump will not work	<ol style="list-style-type: none"> 1. Excessive wear on internal parts 	<ol style="list-style-type: none"> 1. Disassemble and repair.

MAINTENANCE





Motor will not work 1. Excessive wear on internal parts 1. Disassemble and repair.

NOTE: If flow meter is available, check pressure and flow volume for all suspected hydraulic problems.





If the solution to your problem cannot be found in this section, call the Technical Service representative at the number shown on the front cover of this manual.

MAINTENANCE

TORQUE SPECIFICATIONS

Torque for Standard Fasteners														
Nominal Dia.	threads per inch	 Grade 2			 Grade 5			 Grade 8			 Grade 9			
		Tightening Torque			Tightening Torque			Tightening Torque			Tightening Torque			
		Lubed	Dry Plated	Dry plain	Lubed	Dry Plated	Dry plain	Lubed	Dry Plated	Dry plain	Lubed	Dry Plated	Dry plain	
(in.)		K = 0.15	K = 0.17	K = 0.20	K = 0.15	K = 0.17	K = 0.20	K = 0.15	K = 0.17	K = 0.20	K = 0.15	K = 0.17	K = 0.20	
Unified Coarse Thread Series														
1/4	20	49 in-lbs	59 in-lbs	66 in-lbs	76 in-lbs	86 in-lbs	101 in-lbs	107 in-lbs	122 in-lbs	143 in-lbs	126 in-lbs	143 in-lbs	168 in-lbs	
5/16	18	101	122	135	157	178	209	221	251	295	259	294	346	
3/8	16	15 ft-lbs	18 ft-lbs	20 ft-lbs	23 ft-lbs	26 ft-lbs	31 ft-lbs	33 ft-lbs	37 ft-lbs	44 ft-lbs	38 ft-lbs	43 ft-lbs	51 ft-lbs	
7/16	14	24	29	32	37	42	49	52	59	70	61	70	82	
1/2	13	37	44	49	57	64	75	80	90	106	94	106	125	
9/16	12	53	63	70	82	92	109	115	130	154	135	153	180	
5/8	11	73	87	97	113	128	150	159	180	212	186	211	248	
3/4	10	129	155	172	200	227	267	282	320	376	331	375	441	
7/8	9	125	150	167	322	365	429	455	515	606	533	604	710	
1	8	187	225	250	483	547	644	681	772	909	799	905	1065	
1 1/8	7	266	319	354	596	675	794	966	1095	1288	1132	1283	1510	
1 1/4	7	375	450	500	840	952	1121	1363	1545	1817	1597	1810	2130	
1 1/2	6	652	783	869	1462	1657	1950	2371	2688	3162	2779	3150	3706	
Fine Thread Series														
1/4	28	56 in-lbs	68 in-lbs	75 in-lbs	87 in-lbs	99 in-lbs	116 in-lbs	123 in-lbs	139 in-lbs	164 in-lbs	144 in-lbs	163 in-lbs	192 in-lbs	
5/16	24	112	135	150	174	197	231	245	278	327	287	325	383	
3/8	24	17 ft-lbs	20 ft-lbs	23 ft-lbs	26 ft-lbs	30 ft-lbs	35 ft-lbs	37 ft-lbs	42 ft-lbs	49 ft-lbs	43 ft-lbs	49 ft-lbs	58 ft-lbs	
7/16	20	27	32	36	41	47	55	58	66	78	68	78	91	
1/2	20	41	49	55	64	72	85	90	102	120	105	120	141	
9/16	18	59	71	78	91	103	121	128	146	171	151	171	201	
5/8	18	82	99	110	127	144	170	180	204	240	211	239	281	
3/4	16	144	173	192	223	253	297	315	357	420	369	418	492	
7/8	14	138	165	184	355	403	474	502	568	669	588	666	784	
1	14	210	252	280	542	614	722	765	867	1020	896	1016	1195	
1 1/8	12	298	357	397	668	757	890	1083	1227	1444	1269	1439	1693	
1 1/4	12	415	498	553	930	1055	1241	1509	1710	2012	1768	2004	2358	
1 1/2	12	734	880	978	1645	1865	2194	2668	3024	3557	3127	3544	4169	

Torque values for 1/4 and 5/16-in series are in inch-pounds. All other torque values are in foot-pounds. K = 0.15 for "lubricated" conditions D = Nominal Diameter
 Torque values calculated from formula T=KDF, where K = 0.17 for zinc plated and dry conditions F = Clamp Load
 K = 0.20 for plain and dry conditions

Torque-Tension Relationship for Metric Fasteners													
		Class 4.6			Class 8.8			Class 10.9			Class 12.9		
		 4.6			 8.8			 10.9			 12.9		
Nominal Dia.	Pitch	Tightening Torque			Tightening Torque			Tightening Torque			Tightening Torque		
		Lubed	Dry Plated	Dry plain	Lubed	Dry Plated	Dry plain	Lubed	Dry Plated	Dry plain	Lubed	Dry plain	
(mm)		K = 0.15	K = 0.17	K = 0.20	K = 0.15	K = 0.17	K = 0.20	K = 0.15	K = 0.17	K = 0.20	K = 0.15	K = 0.20	
		(ft-lbs)	(ft-lbs)	(ft-lbs)	(ft-lbs)	(ft-lbs)	(ft-lbs)	(ft-lbs)	(ft-lbs)	(ft-lbs)	(ft-lbs)	(ft-lbs)	
3	0.5	0.28	0.32	0.38	0.73	0.82	0.97	1.0	1.2	1.4	1.2	1.6	
3.5	0.6	0.44	0.50	0.59	1.1	1.3	1.5	1.6	1.9	2.2	1.9	2.5	
4	0.7	0.66	0.74	0.87	1.7	1.9	2.3	2.4	2.7	3.2	2.8	3.8	
5	0.8	1.3	1.5	1.8	3.4	3.9	4.5	4.9	5.5	6.5	5.7	7.6	
6	1	2.3	2.6	3.0	5.8	6.6	7.7	8.3	9.4	11	9.7	13	
6	1.25	2.1	2.3	2.7	5.3	6.0	7.0	7.6	8.6	10	8.8	12	
7	1	3.8	4.3	5.0	9.7	11	13	14	16	19	16	22	
8	1	5.9	6.6	7.8	15	17	20	22	24	29	25	34	
8	1.25	5.5	6.2	7.3	14	16	19	20	23	27	24	31	
10	1.25	11	13	15	29	33	39	42	48	56	49	66	
10	1.5	11	12	14	28	32	37	40	45	53	47	62	
12	1.25	21	23	28	53	60	71	76	86	101	89	119	
12	1.5	20	22	26	51	58	68	73	82	97	85	113	
12	1.75	19	21	25	49	55	65	70	79	93	81	108	
14	1.25	26	29	34	66	75	89	95	108	127	111	148	
14	1.5	28	32	37	72	82	96	103	117	138	121	161	
14	2	30	34	40	78	88	104	111	126	148	130	173	
16	1.5	50	57	67	129	146	171	184	208	245	215	287	
16	2	47	53	62	121	137	161	173	196	230	202	269	
18	1.5	73	82	97	187	212	249	268	303	357	313	417	
18	2.5	65	73	86	167	189	222	239	270	318	279	372	
20	2.5	91	104	122	236	267	314	337	382	449	394	525	

Clamp load calculated as 75% of the proof load for specified bolts. K = 0.15 for "lubricated" conditions D = Nominal Diameter
 All torque values are listed in foot-pounds K = 0.17 for zinc plated, dry conditions F = Clamp Load
 Torque values calculated from formula T=KDF, where K = 0.20 for plain and dry conditions

* These are intended to be general specifications. See tractor operators or service manual for exact specifications for your unit.

MAINTENANCE

LUBRICATION RECOMMENDATIONS

Description	Application	General Specification	Recommended Mobil Lubricant
Tractor Hydraulics	Reservoir	JD-20C MF M1135,M1141 FNHM2C134D (FNH201)	Mobilfluid 424
Mower Hydraulics	Reservoir		
Cold Temperatures 0 F Start-Up		ISO 46 Anti-Wear - Low Temp	Mobil DTE 15M
Normal Temperatures 10 F Start-Up		JD-20C MF M1135,M1141 FNH M2C134D (FNH201)	Mobilfluid 424
Normal Temperatures 15 F Start-Up		ISO 46 Anti-Wear	Mobil DTE 25
High Operating Temp. Above 90 F		ISO 100 Anti-Wear	Mobil DTE 18M
Flail Rear Gearbox	Grease	PAO Synthetic Extreme Pressure Gear Lube	Mobil SHC 75W-90 Mobil 1 Synthetic Gear
Cutter Shaft & Ground Roller Shaft (Flail)	Grease Gun	Lithium-Complex Extreme Pressure NLGI 2 - ISO 320	Mobilgrease CM-S
Drive Shaft Coupler (Flail and Rotary)	Grease Gun	Lithium-Complex Extreme Pressure NLGI2 - ISO 320	Mobilgrease CM-S
Drive Shaft Yoke, U-Joint & Stub Shaft	Grease Gun	Lithium-Complex Extreme Pressure NLGI2 - ISO 320	Mobilgrease CM-S
Boom Swivel Boom Cylinder Pivots (Rotary & Flail Boom)	Grease Gun	Lithium-Complex Extreme pressure NLGI2 - ISO 320	Mobilgrease CM-S
Deck Boom Pivot & Deck Stop Adjustment (Rotary & Flail)	Grease Gun	Lithium-Complex Extreme pressure NLGI 2 - ISO 320	Mobilgrease CM-S
Deck Spindle (Rotary)	Grease Gun	Tiger Spindle Lubricant part number 06540000	Mobilith SHC 220

MAINTENANCE

POLYCARBONATE CARE & MAINTENANCE

The proprietary UV and Abrasion Resistant surface coating on SHIELDS® SUPERCOATED™ polycarbonate significantly improves performance. Periodic cleaning using proper procedures and compatible cleaners are recommended to prolong service life. Tiger Corp. polycarbonate is SUPERCOATED™ on both sides.

CLEANING THE SUPERCOAT™ HARD-COAT

1. Wash with a mild solution of soap or detergent and lukewarm water.
2. Using a soft cloth or sponge, gently wash the sheet to loosen dirt and grime and rinse well with clean water.
3. To prevent water spotting, thoroughly dry with chamois or cellulose sponge.
4. Avoid the use of abrasive cleaners, squeegees and/or other cleaning implements that may mar or gouge the coating.

CLEANING AGENTS WHICH HAVE BEEN FOUND TO BE COMPATIBLE UNDER LABORATORY CONDITIONS:

- Aqueous Solutions of Soaps and Detergents
Windex¹ Top Job² Joy² Mr. Clean²
Fantastik³ Formula 409⁴ Sumalight D12 Brucodecid
- Organic Solvents
Butyl Cellosolve Kerosene Hexel, F.O. 554 Naphtha (VM&P grade)
Neleco-Placer Turco 5042
- Alcohols
Methanol Isopropyl

All residual organic solvents should be removed with a secondary rinse.

GRAFFITI REMOVAL

Butyl cellosolve (for removal of paints, marking pen inks, lipstick, etc.). The use of masking tape, adhesive tape or lint removal tools works well for lifting off old weathered paints.

To remove labels, stickers, etc., the use of kerosene or VM&P naphtha are generally effective. When the solvent will not penetrate sticker material, apply heat (hair dryer) to soften the adhesive and promote removal.

IMPORTANT: If a material is found to be incompatible in a short-term test, it will usually be found to be incompatible in the field. The converse, however, is not always true. Favorable performance is no guarantee that actual end-use conditions have been duplicated. Therefore, these results should be used as a guide only and it is recommended that the user test the products under actual end-use conditions.

MAINTENANCE

RECOMMENDED FILLING INSTRUCTIONS FOR HYDRAULIC RESERVOIRS

When filling or checking the oil level, the unit should be parked on a level surface, shut “OFF”, and allowed sufficient time to cool to ambient temperature. Use caution when removing the pressurized breather. Do not place face over opening when removing the breather.

The reservoir should be filled to the top of the lower sight glass on the side of the tank. Do not over-fill. The reservoir has been over-filled when oil is visible in the upper sight glass. If tank has too much oil, the excess may be expelled through the pressurized breather.

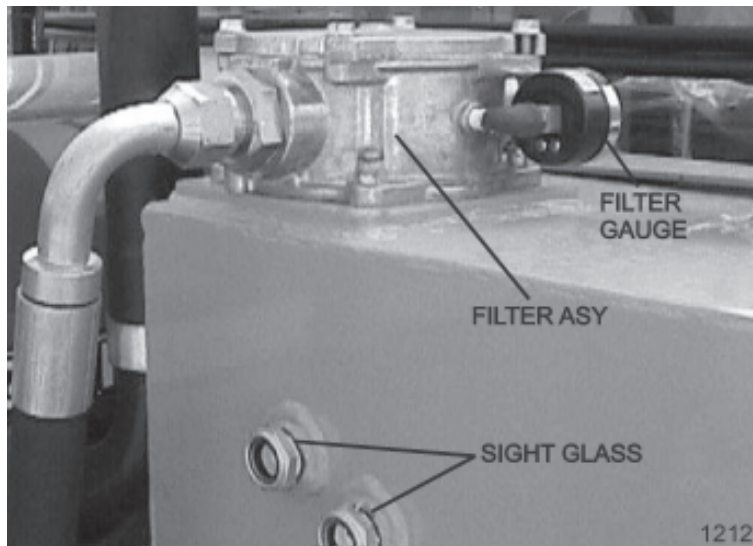

DETAILED MAINTENANCE

REPLACING IN-TANK HYDRAULIC FILTER:

Loosen the four bolts on the top cover of the filter housing. Turn cover counter-clockwise until cover is free. Remove and replace filter. Replace top cover and cover bolts in opposite order as removed.

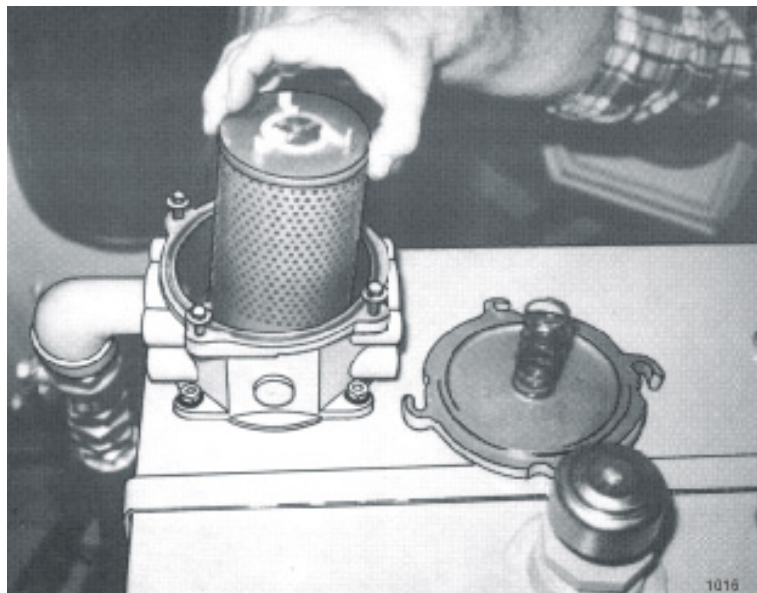

MAINTENANCE

DETAILED MAINTENANCE

REPLACING HIGH PRESSURE HYDRAULIC FILTER ELEMENT:

Assure system has been shut down and de-pressurized. Locate High Pressure Filter housing. Confirm that the element that is about to be installed matches the element p/n on the filter model tag. Example: V3.0510-06 (world line 100, HD049 model) Locate the bottom of the High Pressure Bowl, and use the appropriate spanner wrench –or- ratchet that matches the hex pattern. Using the spanner wrench -or- ratchet and turning in a counterclockwise rotation, (looking at the bottom of the bowl) remove the bowl from the head, The first couple rotations will seam tight as the o-ring passes the sealing flats, once the o-ring has cleared the sealing flats the bowl should spin freely. Taking care not to drop the bowl, finish removing the bowl from the head. **WARNING:** bowl will be full of oil! Pour the oil from the bowl into a container, this oil should be considered contaminated due to the flow direction through the element is outside ~ in. Clean the inside of the bowl if “dirt” is present. Remove the old element from the filter head by pulling with a rotation motion. Dispose of the used element properly. Remove the new element from the packaging. Using your finger, dab and lubricate the o-ring in the top of the new element. Install the new element into and on the mounting boss with in the head; assure that the element is fully seated on the boss. Clean and inspect the o-ring that is affixed in the bowl, lubricate with oil. Using a clockwise rotation, screw the bowl back into the head, assuring that the bowl has not been cross threaded into the head. Continue “tighten” the bowl into the head, using the spanner wrench –or- ratchet, the rotation of the bowl will become tighter once the o-ring engages the sealing flats. Once the bowl has been fully inserted into the head, and the o-ring has reached the sealing flats, the bowl can no longer be “tightened” and bottoms out. Once the bowl has bottomed out, “back-off” the bowl by 1/6 turn, this assures that the o-ring is seated properly with in the sealing flats. Element change out and re-assembly is now complete. Start the machine and inspect the filter area checking that there is no oil leaking from the filter assembly. This is first to be done at 50 hours of operation, then yearly(500 hours) or when indicated by restriction indicator.

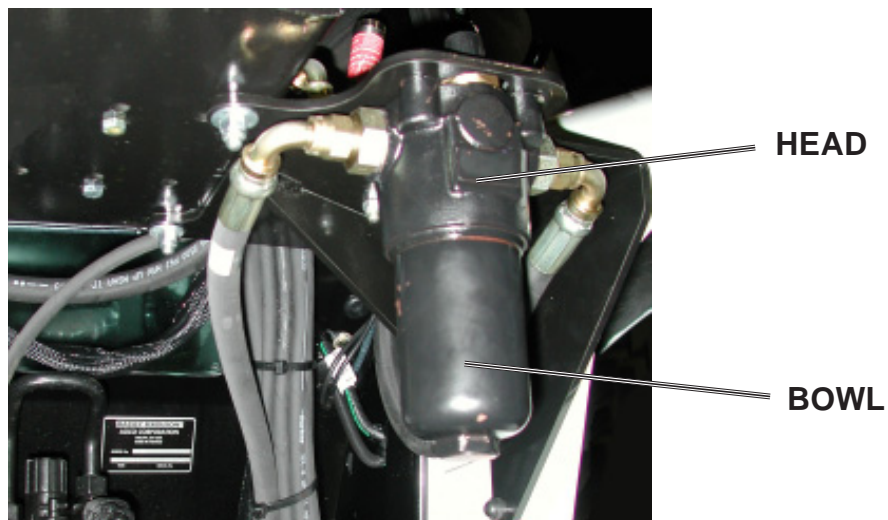

MAINTENANCE

GREASING INNER AND OUTER DRAFT BEAM PIVOT POINTS

Locate the grease zerks on the inner and outer draft beam pivot bosses. Inject Lithium-Complex Extreme Pressure grease conforming to NLGI2-ISO 320 specifications into each zerk until grease protrudes from joints. Grease all pivots daily or every 8 hours of service.

GREASING THE UPPER AND LOWER SHEAVES

Locate the grease zerks on the ends of the upper and lower sheave pins as shown below. Inject Lithium-Complex Extreme Pressure grease conforming to NLGI2-ISO 320 specifications into each pin until it protrudes from the ends. These should also be greased daily or for every 8 hours of service.

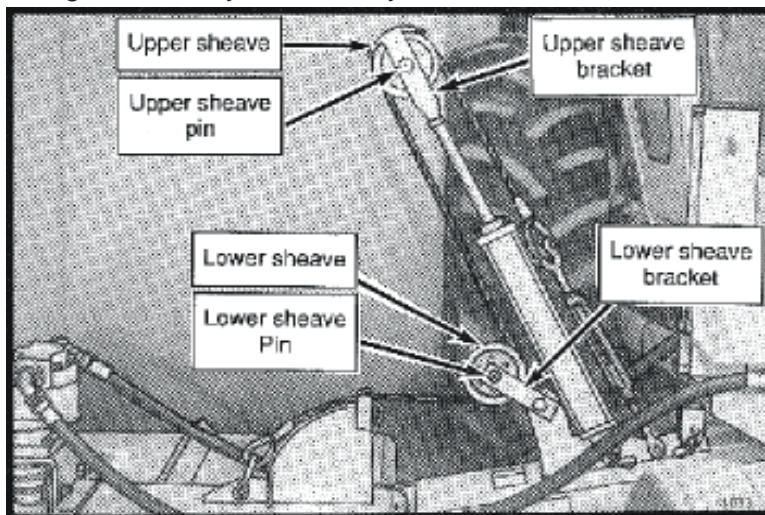

TIGHTENING KNIFE BOLTS AND DISK BOLTS:

After every 8 hours of operation or daily, the Knife Bolts and Disk Bolts should be tightened as follows:

Knife mounting bolts (3ea.) torque to 800 oiled ft. lbs.

Disk mounting bolts (6ea.) torque to 204 dry or 184 oiled ft. lbs.

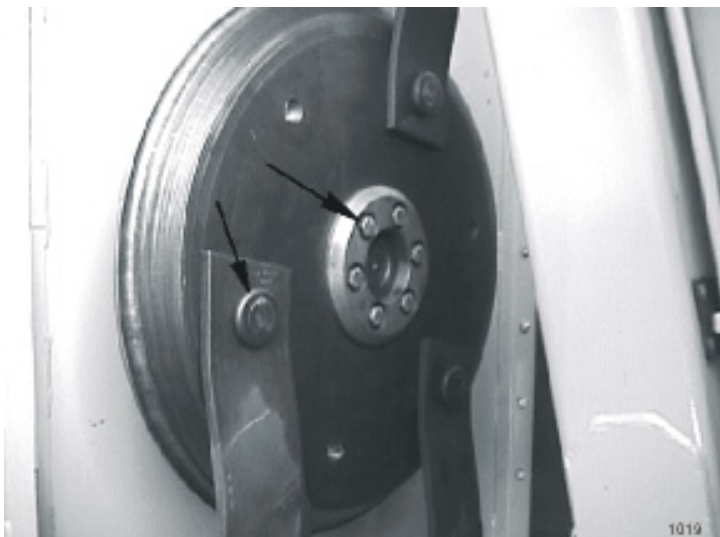

MAINTENANCE

GREASING PUMP DRIVE SHAFT COUPLER

With engine stopped, ensure drive shaft alignment by grasping coupler and sliding back and forth. Coupler should slide freely with approximately 1/8" of end play. If coupler does not slide freely, inspect for loose pump mount bolts, or damaged or loose crank shaft adapter. Inject Lithium-Complex Extreme Pressure grease conforming to NLGI2-ISO 320 specifications into coupler until grease begins to protrude from ends. Grease daily or every 10 hours. Do not over grease.

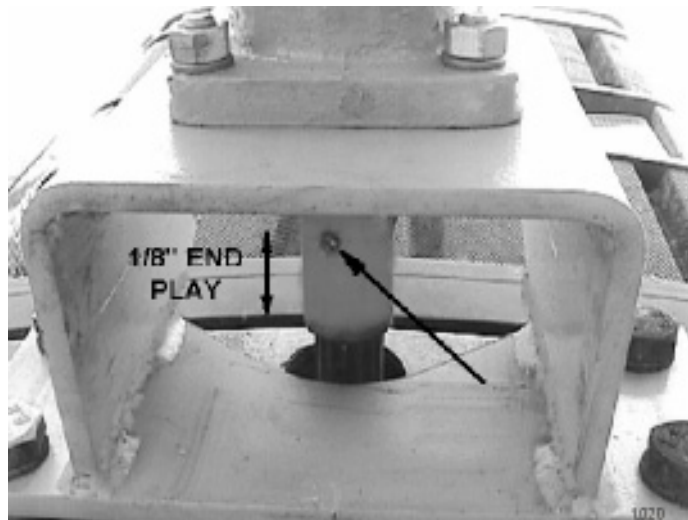

DRIVE SHAFT YOKE, U-JOINT & STUB SHAFT

With engine stopped, inject Lithium-Complex extreme pressure grease conforming to NLGI2-ISO 320 specifications into universal joints and slip yoke until grease appears at the seal. Grease daily or every 10 hours. Do not over grease.

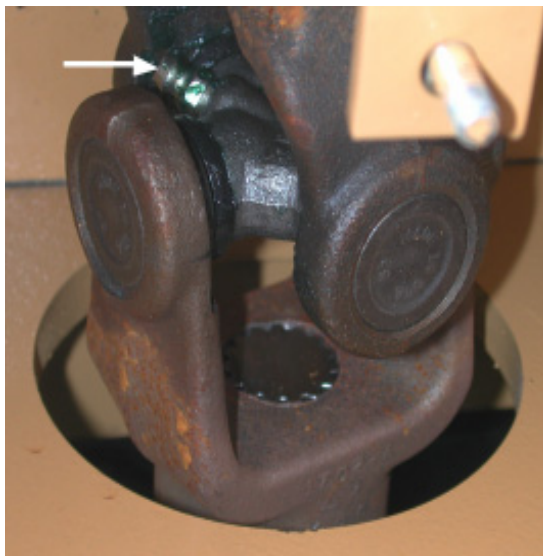

MAINTENANCE

ADJUSTING THE CABLE LIFT

Extend the outboard cylinder until the mower deck touches its stop on the draft beam as shown. NOTE: Make sure the cable turnbuckle is loose enough to allow the cylinder to reach full extension before the head reaches the stop. Now hold the head against the stop and tighten the turnbuckle until the cable is tight. Lower and raise the head to check the adjustment. The head should touch its stop at the same time the cylinder reaches full extension. Tighten turnbuckle lock nuts securely after adjustment is complete.

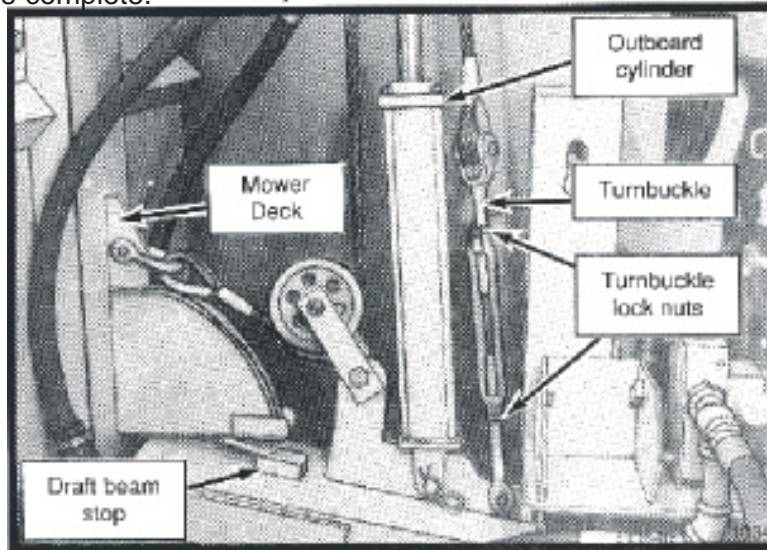

GREASING THE CASTER WHEEL SWIVEL

Locate the grease zerk on the caster wheel swivel boss as shown. Inject Lithium-Complex Extreme Pressure grease conforming to NLGI2-ISO 320 specifications into the boss until the grease protrudes from the ends. Grease daily or every 8 hours of service.

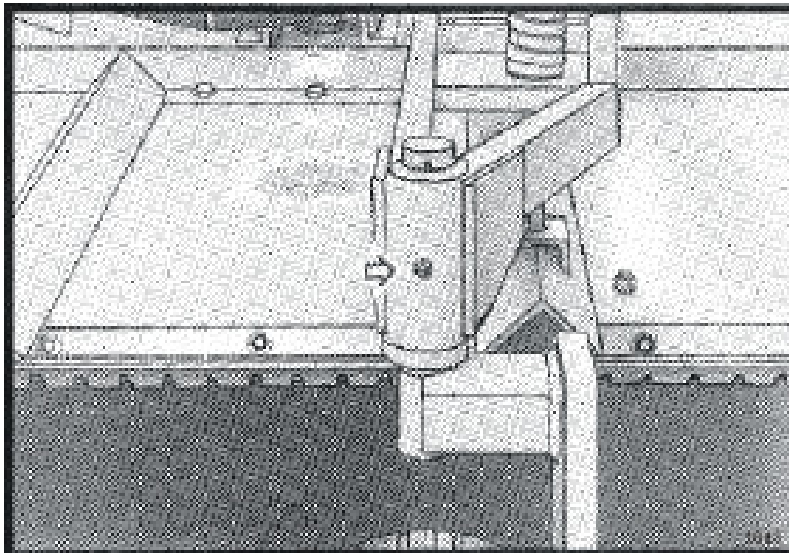

MAINTENANCE

GREASING CASTER FRAME PIVOT POINTS

Locate the grease zerks on the caster frame as shown. Inject Lithium-Complex Extreme Pressure grease conforming to NLGI2-ISO 320 specifications into each zerk until grease begins to protrude from ends. Grease daily or every 8 hours of service.

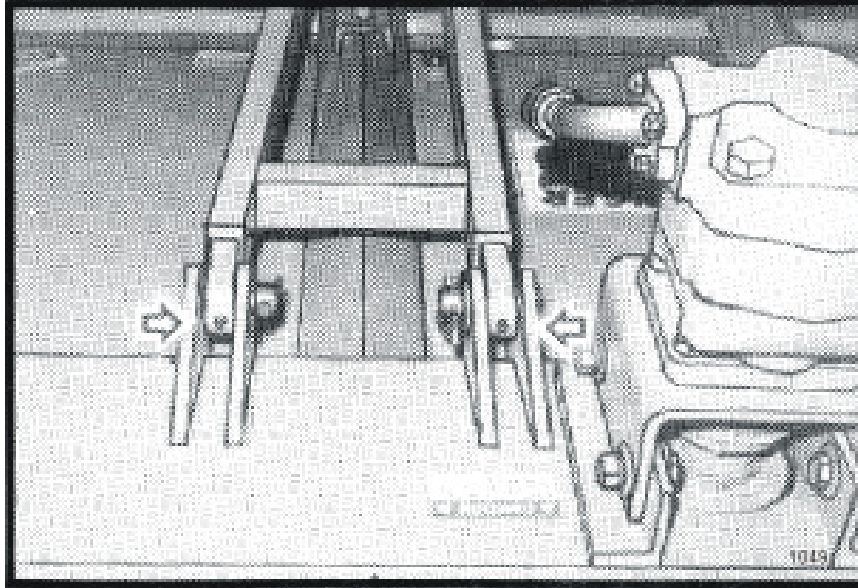

BALL VALVES

The ball valve at the hydraulic reservoir may need to be closed during certain maintenance or repair procedures. **THE BALL VALVES MUST BE OPEN (handle parallel with valve) WHEN TRACTOR IS RE-STARTED OR PUMP IS COUPLED TO MOTOR OR P.T.O. !** Failure to do so may result in component failure!

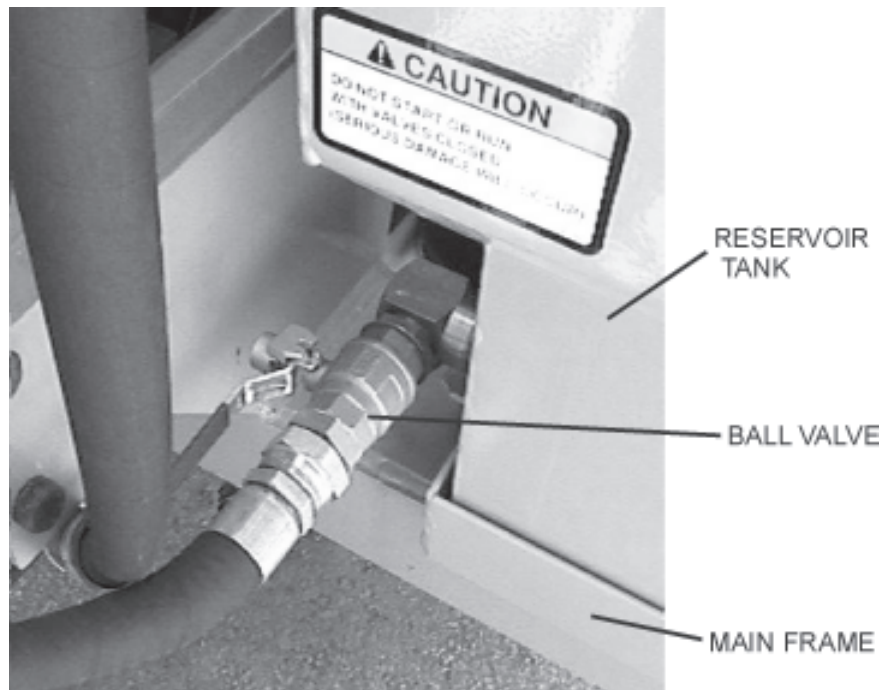

1211

MAINTENANCE

GREASING SPINDLE

Locate grease fitting on inside of deck housing. Inject Tiger Spindle Lubricant, part number 06540000 into spindle housing. Fill with lubricant until lubricant weeps out of the top spindle seal. Lubricate spindle weekly or every 40 hours of use.

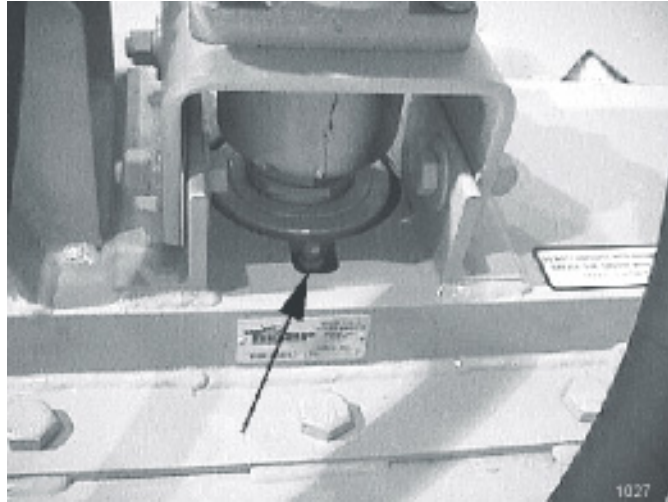

TIGHTENING SPINDLE BOLTS

The spindle mounting bolts should be checked and retorqued daily or every 10 hours of service. Torque the (6) bolts shown below to 331 ft. lbs.



MAINTENANCE

INSPECTION OF ROTARY KNIVES

CAUTION!



Failure to follow the following warnings and instructions may result in serious injury or damage to the equipment or property!

- 1 – **DO NOT** weld on the knife or bolts. Damaged or worn knives must be replaced.
- 2 – Knife must be replaced in sets. Knives with unequal wear may cause serious vibration and resulting structural damage to the mower.
- 3 – The self-locking nuts for the knife mounting bolts must **NOT** be reused. If the self-locking nut is removed from the knife mounting bolt, the nut **must** be replaced with a new self-locking nut.
- 4 – Inspect the condition and tightness of the knife mounting bolts and disk mounting bolts daily.

ROTARY KNIFE REPLACEMENT

- 1 – Be sure you have a complete matching set of new knives for replacement.
- 2 – Remove knives and inspect holes for damage. Also watch for cracks in the disk around the holes.
- 3 – Lube threads with anti-seize, motor oil or grease. Install bolt through knife and disk from bottom side of disk. Install new self-locking nuts and torque them to 800 oiled ft. lbs.
- 4 – The knives should swing freely to absorb shocks from impact when striking objects.

WARNING!



WHEN CUTTING HEAVY BRUSH, KNIFE BOLTS SHOULD BE INSPECTED HOURLY AND RETORQUED TO 1070 dry or 800 oiled FT. LBS.

MAINTENANCE

REPLACEMENT OF ROTARY DISK

CAUTION!



Failure to follow the following warnings and instructions may result in serious injury or damage to the equipment or property!

The bolts that attach the knife mounting disk to the spindle must be grade 8. These 5/8 inch bolts are to be torqued to 225 ft. lbs.

A thread locking agent may be applied to threads of all mounting bolts before they are installed.

Disks must be inspected daily for hairline cracks between spindle mounting bolts or around the knife mounting bolts. These cracks indicate metal fatigue caused by severe abuse. If cracks are present, the disk must be replaced.

Inspect the disk mounting bolts daily when checking tightness of knife mounting bolts. If a disk mounting bolt is loose, it must be removed, threads cleaned, fresh thread locking agent applied, and tightened to proper torque value.

If a knife mounting bolt is loose, the self locking nut must be replaced as a safety precaution. Lubricate threads with anti-seize, grease or motor oil. Install bolts through knife and disk from bottom side of disk. Install self locking nuts and torque them to 800 ft. lbs.

- 1- **WARNING:** The disk alone weighs approximately 210 lbs. Be sure its weight can be supported before attempting to replace. The use of a lift mechanism will ease replacement.
- 2- Remove the six disk mounting bolts and the disk from the spindle.
- 3- Install new disk and align with mounting bolt holes.
- 4- Apply a thread locking agent to all of the mounting bolts and install the bolts through the disk. If a bolt protector is being installed, hold the protector in place and install the bolts through the bolt protector and disk. **NOTE:** Disk mounting bolts must be Grade 8.
- 5- Tighten bolts down and torque to values noted.
- 6- See knife replacement instructions for replacing the knives onto the new disk.

MAINTENANCE

HEAVY DUTY SPINDLE ASSEMBLY INSTALLATION AND BEARING ADJUSTMENT

WARNING! A press **MUST** be used to install bearing cups, bearing cones, and seals. **DO NOT** use a hammer to install races, bearings, or seals. The parts of assembly may be damaged.

NOTE: The grease zerk and gussets are located on the top side of the spindle housing. Be sure the spindle is assembled correctly.

Be sure to wear eye protection and other protective equipment as needed when working on spindle assembly.

THE SPINDLE ASSEMBLY

See the diagram below for identification of spindle parts, while servicing.

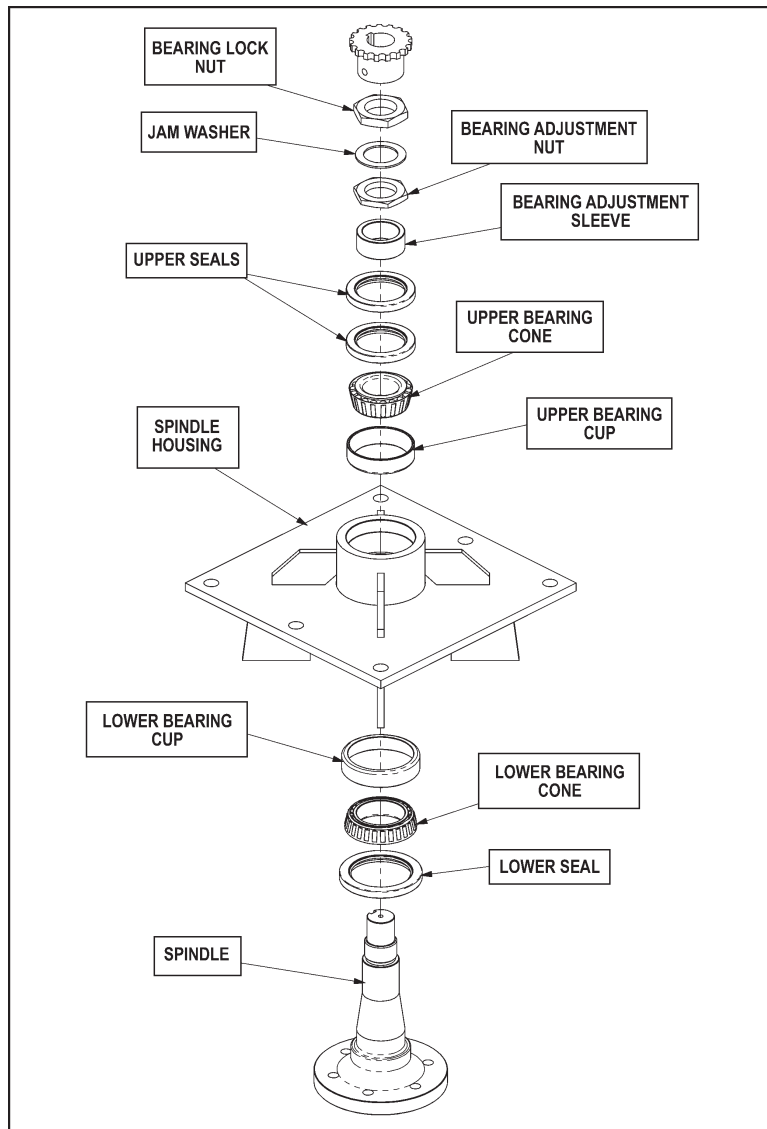

MAINTENANCE

BEARING INSTALLATION

- 1 – Press upper bearing cup into the spindle housing.
- 2 – Turn the spindle housing over and press in the lower bearing cup.
- 3 – Place the lower bearing cone in the bearing cup. Next press the seal into the spindle housing. The inner lip of the seal must be DOWN, towards the bearing, so lubricant is sealed inside the housing.
- 4 – Install the spindle in the housing. Lightly tap the end of the spindle with a soft faced hammer to seat the spindle against the bearing inner race.
- 5 – Turn the spindle housing over (up position) and fill with Tiger Spindle Lubricant (part number 06540000) to the top edge of the upper bearing cup.
- 6 – Support the bottom of the spindle and press the upper bearing cone and bearing adjustment sleeve onto the spindle.

NOTE: The spindle housing must turn freely when seating the bearing cone and sleeve.

7 – Press the two upper seals into the spindle housing. The inner lip of the seals must be UP, away from the bearing, so excess lubricant can escape.

8 – Install the bearing adjustment nut (thin nut) so there is 1/16" clearance between the nut and the sleeve. Install the jam washer, placing the tab into the key-way. Install the bearing lock nut (thin nut) and hand tighten against jam washer and adjustment nut. See the following section for bearing adjustment.

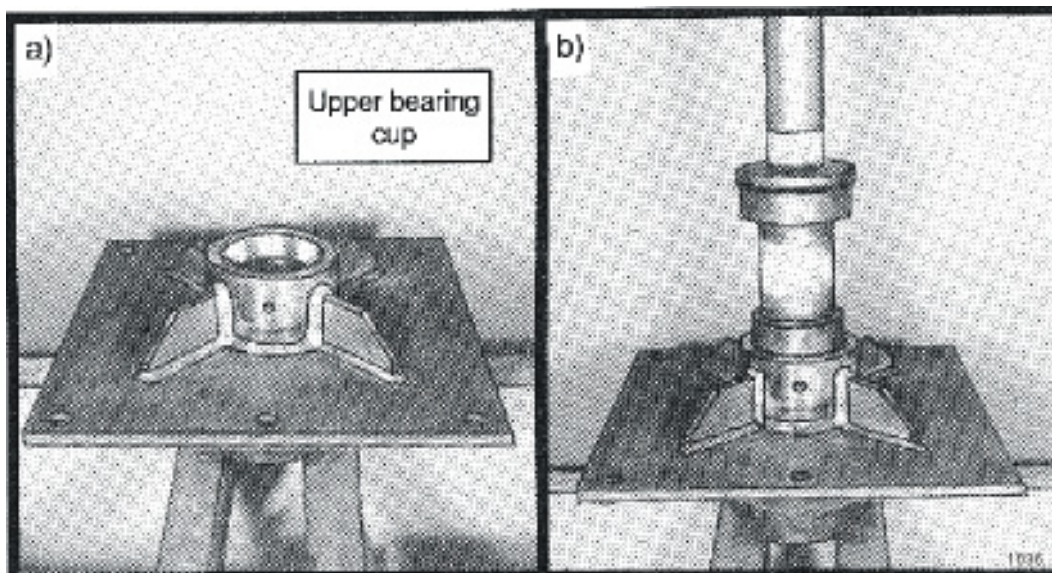

MAINTENANCE

BEARING ADJUSTMENT

- 1 – Clamp the bottom end of the spindle securely in a vise so the spindle housing turns freely.
- 2 – Position a magnetic base dial indicator on the stationary cylinder of the spindle housing. Locate the end of the dial indicator against the flat end of the spindle shaft. The dial indicator will now measure accurately bearing end play.
- 3 – Tighten the bearing adjustment nut until there is .012 inch movement when the spindle housing is pried upward away from the vise jaws.
- 4 – When there is .012 inch free play between the spindle and housing, install the bearing lock nut (thick nut). Hold the adjusting nut securely and tighten the lock nut to 300 ft. lbs. of torque.
- 5 – After the lock nut is tightened, there must be .001 inch to .003 inch of free play when lightly prying up on the spindle housing.

If the end play is correct, .001 inch to .003 inch, bend tabs up on jam washer to prevent the lock nut from loosening.

If the end play is NOT correct, loosen the lock nut and turn the adjustment nut as required and re-tighten the lock nut. Repeat first part of step 5.

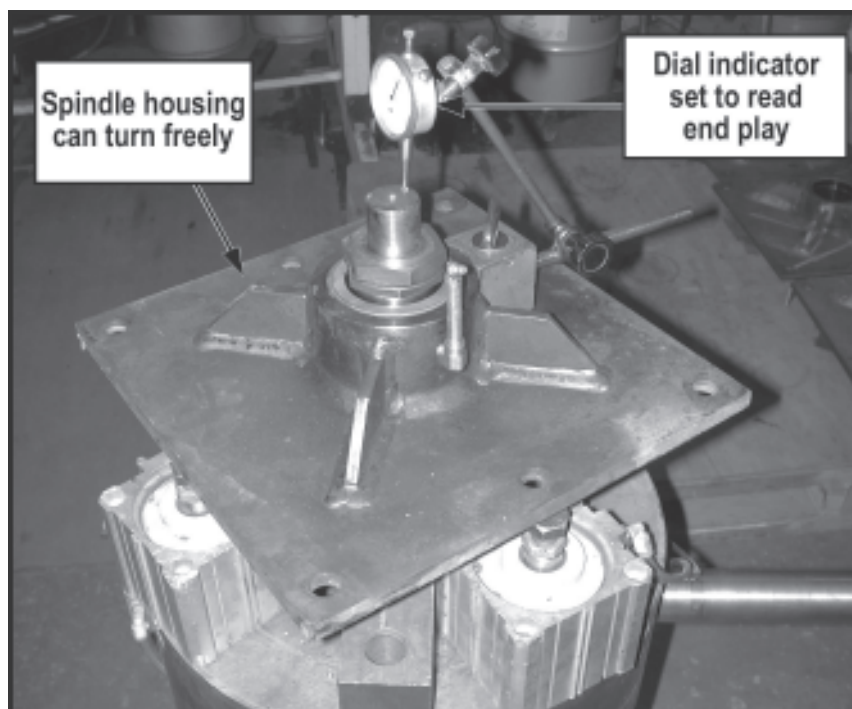

MAINTENANCE

DAILY MAINTENANCE SCHEDULE

The following services should be performed **daily** or every **8 hours** of service, following the detailed maintenance instructions in the operators manual.

- _____ Pump Drive Shaft: If required with drive shaft / coupler check for end play and lubricate at zerks.
- _____ Crankshaft adapter: If equipped with rubber grommets check condition, replace if missing or damaged.
- _____ Pivot points: Inject grease until it appears at ends.
- _____ Hydraulic fittings: Check for leaks with paper or cardboard. Tighten fittings or replace hoses immediately.
- _____ Knives: Inspect for missing or damaged knives, change (only complete sets) as needed.
- _____ Belts: Check / Tighten / Replace belts as needed.
- _____ Main Frame / Deck: Unless otherwise specified retorque bolts according to torque specifications in this section.
- _____ Hydraulic Fluid Level: Add, if required, per fluid recommendations.
- _____ Rear Flail Drive, Bearing
Flange and Shaft Couplers: Grease as instructed in the detailed (if applicable) maintenance section.
- _____ Cutter Shaft and Ground Roller: Grease as instructed in the detailed maintenance section

Service performed by: _____ Date: ____/____/____ Hour
Meter: _____

Maintenance Section

** This page may be copied and used as part of the daily maintenance routine.

72-7520 TWIN ROTARY, CAB, WOC, TRR, 2WD, 4WD

**PARTS
SECTION**

PARTS ORDERING GUIDE

The following instructions are offered to help eliminate needless delay and error in processing purchase orders for the equipment in this manual.

1. The Parts Section is prepared in logical sequence and grouping of parts that belong to the basic machine featured in this manual. Part Numbers and Descriptions are given to help locate the parts and quantities required.

2. The Purchase Order must indicate the **Name and Address** of the person or organization ordering the parts, **who should be charged**, and if possible, the **serial number of the machine** for which the parts are being ordered.

3. The purchase order must clearly list the **quantity of each part**, the complete and correct **part number**, and the basic **name of the part**.

4. The manufacturer reserves the right to substitute parts where applicable.

5. Some parts may be unlisted items which are special production items not normally stocked and are subject to special handling. Request a quotation for such parts before sending a purchase order.

6. The manufacturer reserves the right to change prices without prior notice.

NOTE: When ordering replacement decals, refer to the part numbers and descriptions listed in the safety section in the front of this manual.



1000

For maximum safety and to guarantee optimum product reliability, always use genuine **Tiger** replacement parts. The use of inferior replacement parts may cause premature or catastrophic failure which could result in serious injury or death.

Direct any questions regarding parts to:

Tiger Corporation
3301 N. Louise Ave.
Sioux Falls, SD 57107
1-800-843-6849
1-605-336-7900

PARTS SECTION TABLE OF CONTENTS

SECTION	ASSEMBLY	PAGE
TRACTOR SPECIFIC PARTS:		
TRACTOR MOUNT KIT - MAIN FRAME, 2-4WD	06100919	5-4
TRACTOR MOUNT KIT - HYDRAULICS, 2-4WD	06100919	5-6
DRAFT BEAM CYLINDER HOOKUP		5-8
LIFT VALVE - JD72-7520 3SP, CAB (ORIGINAL)	06100916	5-10
LIFT VALVE - JD72-7520 3SP, CAB (2004 UPDATE)		5-12
LIFT VALVE - JD66-6715 3 SP, CAB (ORIGINAL)	06100847	5-14
LIFT VALVE - JD66-6715 3 SP, CAB (2004 UPDATE)		5-16
END COVER (2004 UPDATE)		5-18
HYDRAULIC COOLER - OLD	06100964	5-19
HYDRAULIC COOLER - NEW	06100996	5-20
SOLENOID BRAKE VALVE ASSEMBLY	34115	5-21
SOLENOID VALVE WIRING	1236	5-22
COMMON PARTS SECTION:		6-1

TRACTOR MOUNT KIT - MAIN FRAME,CAB,W/C,2WD,4WD

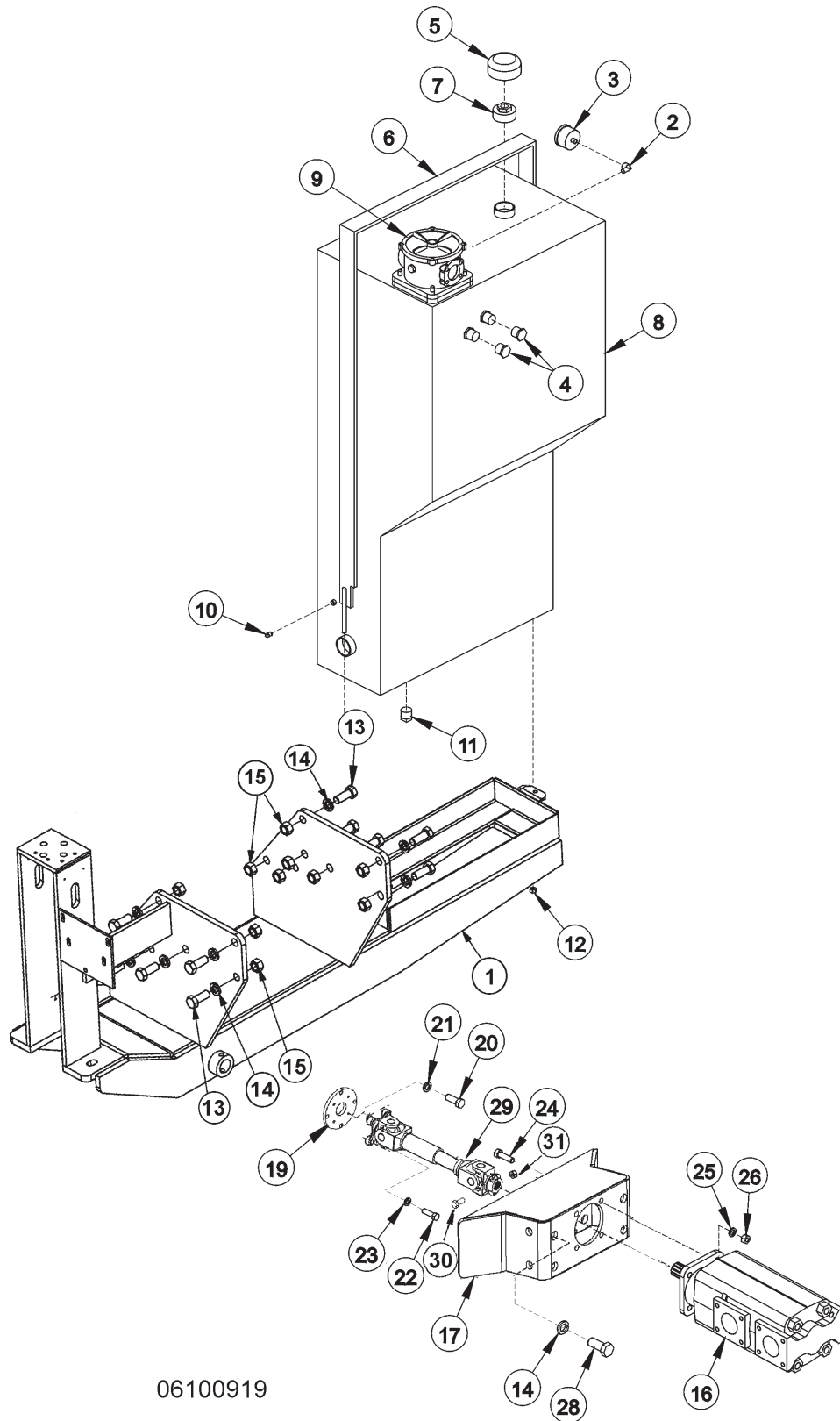

06100919

TRACTOR MOUNT KIT - MAIN FRAME,CAB,W/C,2WD,4WD

ITEM	PART NO.	QTY	DESCRIPTION
1	34801	1	MAIN FRAME
2	TF4888	1	STREET ELBOW
3	6T0649	1	FILTER GAUGE
4	6T1209	2	TANK SIGHT GLASS
5	31004	1	PRESSURE CAP
6	28191B	1	TANK STRAP
	34169	AVAIL.	RESERVOIR TANK ASSY.
7	33700	1	REDUCER BUSHING
8	28192D	1	HYDRAULIC RESERVOIR TANK
9	34066	1	IN-TANK FILTER ASSEMBLY
10	6T4197	1	PIPE PLUG - 1/8"
11	6T4200	1	PIPE PLUG - 3/4"
12	21627	2	NYLOCK NUT - 3/8"
13	31731	14	CAPSCREW - 20MM X 50MM
14	24881	4	LOCKWASHER - 20MM
15	31722	12	HEX NUT - 20MM
16	06504002	1	TANDUM HYDRAULIC PUMP
17	34993	1	PUMP MOUNTING BRACKET
19	34998	1	CRANKSHAFT ADAPTER SPACER
20	23113	4	CAPSCREW - 10MMx30MM
21	32691	4	LOCKWASHER - 10MM
22	21680	4	CAPSCREW - 7/16" X 1 1/4" NC
23	21989	4	LOCKWASHER - 7/16"
24	21732	4	CAPSCREW - 1/2" X 1-3/4" NC
25	21990	4	LOCKWASHER - 1/2"
26	21725	4	HEX NUT - 1/2"
28	24860	4	CAPSCREW - 20MM X 40MM
29	34999	1	DRIVE SHAFT
30	21658	1	CAPSCREW 7/16" x 2"
31	34848	1	NYLOCK NUT 7/16" NF

TRACTOR MOUNT KIT - HYDRAULICS, 2WD, 4WD

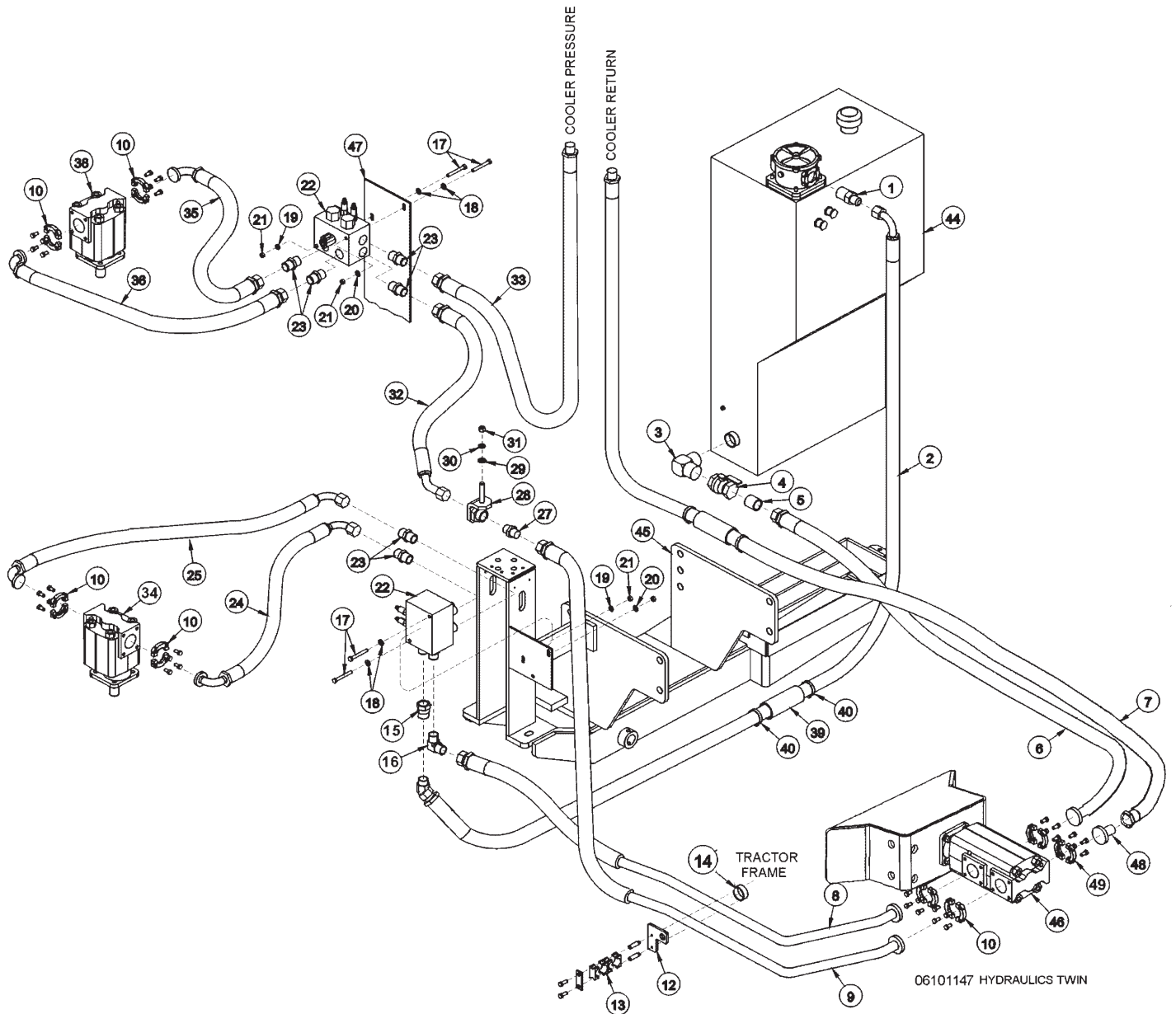

TRACTOR MOUNT KIT - HYDRAULICS, 2WD, 4WD

ITEM	PART NO.	QTY.	DESCRIPTION
1	34064	1	ADAPTER 1 1/4" X 1"
2	06500012	1	HOSE,1 1/4 x 90 (1 1/4 FJX 45 x 1 1/4 90) 90
3	34068	1	ELBOW 1 1/2MP X 1 1/4MOR
4	34069	1	BALL VALVE 1 1/4"
5	34067	2	NIPPLE 1 1/4" X 1 1/4"
6	06500123	1	HOSE,1 1/4x77(24FLGx1 1/4FJ)
7	06500124	1	HOSE,1x241(1MJx1 1/4FJX)
8	06506000	1	HOSE 1" X 75"
9	06500011	1	HOSE 1" X 176"
10	TF4852	6	FLANGE KIT #20
11	34075	2	CLAMP KIT 1"
12	34626	2	BRACKET, TUBE / CLAMP
13	34076	2	CLAMP KIT 1"
14	24849	2	SPACER, 7/8 ID X 1-1/4 OD X 5/8
15	06503000	1	ADAPTER 10RB X 1-1/4 MJ
16	34117	1	ELBOW 1" MORB X 1" MJIC90
17	21644	4	CAPSCREW 3/8" X 5"
18	22016	4	FLATWASHER 3/8"
19	21988	2	LOCKWASHER 3/8"
20	6T2665	2	STAR LOCKWASHER 3/8"
21	21625	4	HEX NUT 3/8"
22	34115	2	SOLENOID BRACK VALVE
23	33555	2	ADAPTER 1" MORB X 1" MJIC
24	34161	1	HOSE 1" X 101"
25	34162	1	HOSE 1" X 98"
27	TF4868	1	SWIVEL 1" MP
28	23283A	1	UNION BLOCK 1"
29	22018	1	FLATWASHER 1/2"
30	21990	1	LOCKWASHER 1/2"
31	21725	1	HEX NUT 1/2"
32	34635	1	HOSE 1" X 68"
33	06500036	1	HOSE,1 x 150(1FJX x 1MJ)
34	23172	1	MOTOR (M365-1 1/2 GEAR)
35	06500086	1	HOSE 1" X 33"
36	06500087	1	HOSE 1" X 40"
38	22680	2	MOTOR 2"
39	6T3200	2	SPLIT HOSE
40	23568	4	HOSE CLAMP
41	6T1823	24	ZIP TIE 14" LG
42	6T1822	8	ZIP TIE 8" LG
44	*	REF	HYDRAULIC TANK - REFER TO MAIN FRAME PARTS
45	*	REF	MAIN FRAME - REFER TO MAIN FRAME PARTS
46	*	REF	PUMP - REFER TO MAIN FRAME PARTS
47	*	REF	DECK - REFER TO COMMON SECTION, DECK PARTS
48	06503024	1	ADAPTER,1 1/4 MJ x 24 FLG
49	TF4854	2	FLANGE KIT #24

NOTE:Band hoses together with zip ties wherever loose. Where hoses may contact the frame or other edges, wrap with split hose and secure with hose clamps or zip ties.

TRACTOR MOUNT KIT - CYLINDER HOOKUP

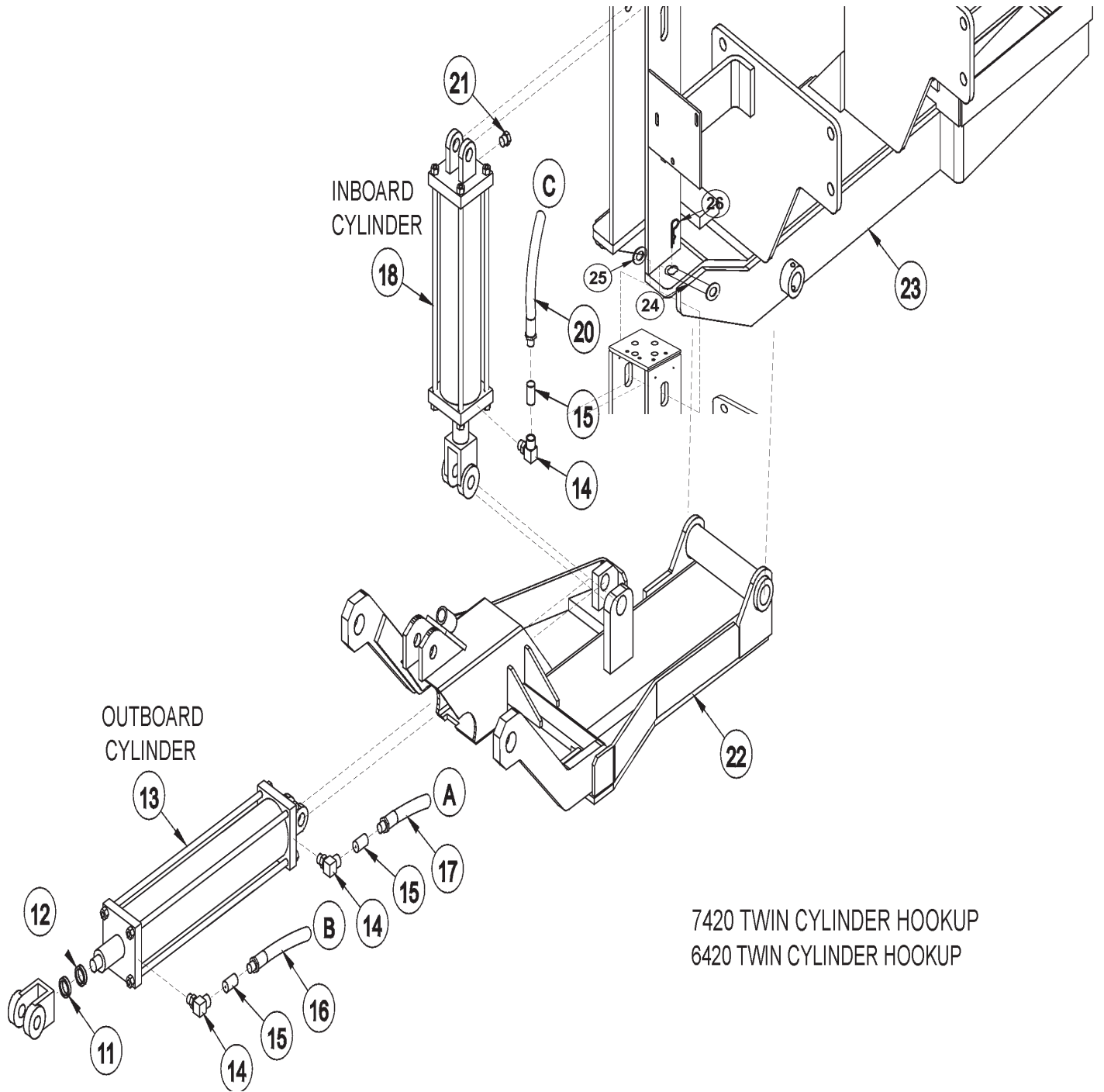

TRACTOR MOUNT KIT - CYLINDER HOOKUP

ITEM	PART NO.	QTY.	DESCRIPTION
11	22076	1	SPACER 1/4" (AS REQUIRED)
12	22077	1	SPACER 5/16" (AS REQUIRED)
13	25343	1	OUTBOARD CYLINDER 3" X 12"
14	34244	3	FITTING 1/2" X 90
15	34396	3	RESTRICTOR NPT
16	*	REF	HOSE - REFER TO COMBO LIFT VALVE
17	*	REF	HOSE - REFER TO COMBE LIFT VAVLE
18	6T0151R	1	INBOARD CYLINDER 3" X 10"
19	31189	1	RESTRICTOR .0625
20	*	1	HOSE - REFER TO COMBO LIFT VALVE
21	6T4258	1	BREATHER 1/2"
22	*	REF	DRAFT BEAM - REFER TO COMMON ASY PARTS
23	*	REF	MAIN FRAME - REFER TO MAIN FRAME PARTS
24	6T3005	1	PIN
25	22023	1	WASHER
26	6T3004	1	R-CLIP

LIFT VALVE - JD72-7520 TWIN, 3SP, CAB (ORIGINAL REMOTE)

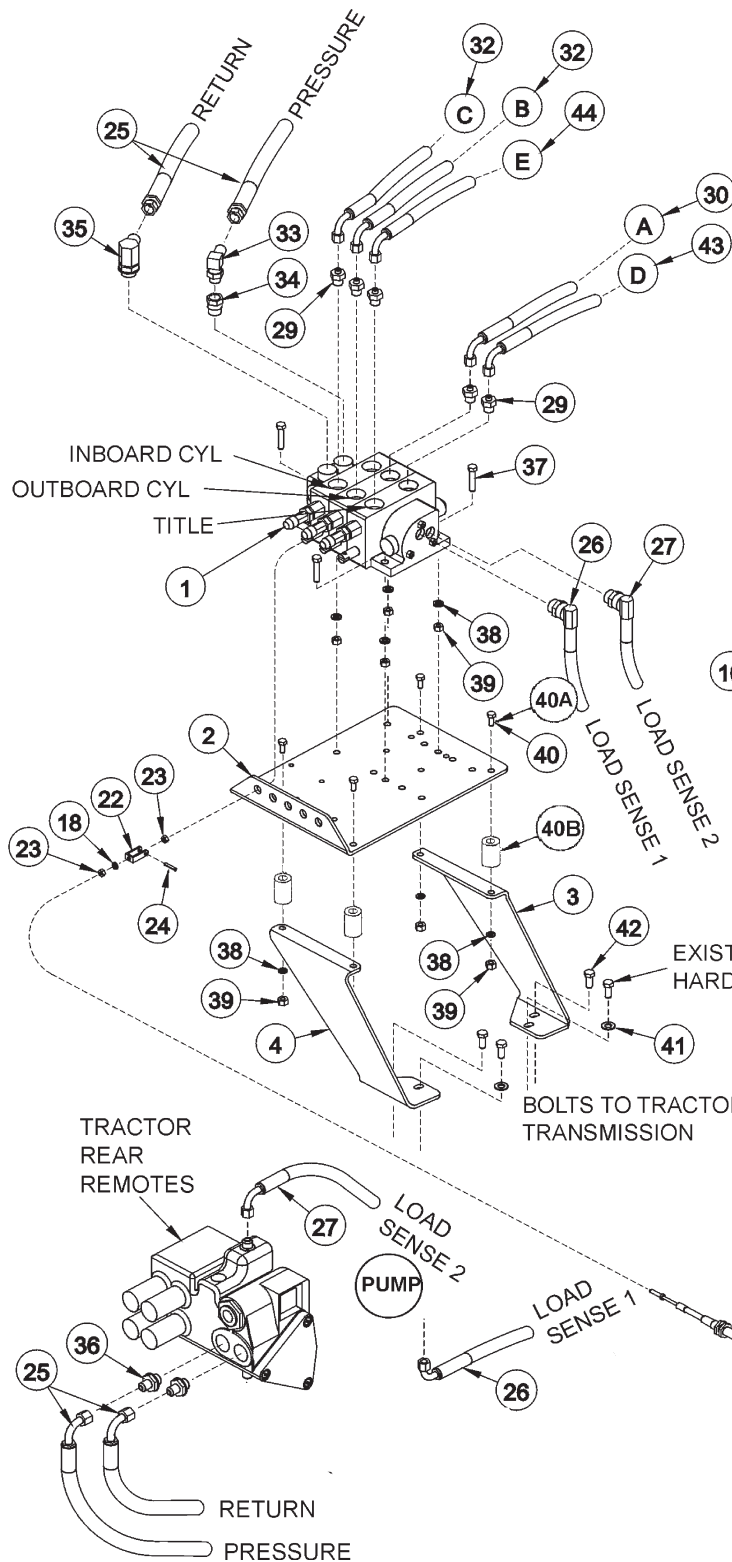

HOSE ROUTING

- A - TO OUTBOARD CYLINDER GLAND
- B - TO OUTBOARD CYLINDER BUTT
- C - TO INBOARD CYLINDER GLAND
- D - TO TILT CYLINDER BUTT
- E - TO TILT CYLINDER GLAND

06100916

NOTE: REFER TO THE END COVER PAGE FOR THE SERIAL NUMBERS OF THE UPDATED REAR REMOTES.

LIFT VALVE - JD72-7520 TWIN, 3SP, CAB (ORIGINAL REMOTE)

ITEM	PART NO.	QTY.	DESCRIPTION
1	31324	1	3 SPOOL VALVE HUSCO
2	34622	1	VALVE MOUNTING PLATE
3	34621	1	VALVE MOUNTING ANGLE, LF
4	34620	1	VALVE MOUNTING ANGLE, RF
5	34521	1	SWITCH BOX, TWIN
6	23865B	1	CABLE CONTROL MOUNTING BRACKET
7	6T1251	3	CABLE CONTROL BOX
8	34623	3	CONTROL CABLE 122"
9	30750A	1	SUPPORT BRACKET
10	22903	2	CAPSCREW 1/4" X 5-1/2
11	21545	1	CAPSCREW 1/4" X 6" NC
12	21635	3	CAPSCREW 3/8" X 2 1/4"
14	22016	3	FLATWASHER 3/8"
15	21627	3	NYLOCK NUT 3/8"
16	6T3200	2	SPLIT HOSE 6" LONG
17	28503	1	TRIMLOCK 9/16"
18	21986	7	LOCKWASHER 1/4"
19	21525	3	HEX NUT 1/4"
20	33534	1	CAPSCREW 10MM X 20MM (1.5 PITCH)
21	32691	1	LOCKWASHER 10MM
22	6T4411	3	CABLE CLEVIS
23	21500	6	HEX NUT 1/4" UNF
24	6T3017	3	ROLL PIN
25	34612	2	HOSE, 1/2" X 34" (PRESSURE & RETURN)
26	34617	1	HOSE 1/4" X 26" (LOAD SENSE 1)
27	34616	1	HOSE 1/4" X 18" (LOAD SENSE 2)
29	32807	5	ADAPTER
30	06500000	1	HOSE, 1/4" X 131"
32	33364	2	HOSE, 1/4" X 120"
33	33382	1	ELBOW, 1/2"
34	32678	1	ADAPTER 5/8" x 1/2"
35	33383	1	ELBOW 5/8" x 1/2"
36	33463	2	ADAPTER 22 MM
37	21633	4	CAPSCREW 3/8" X 1 3/4"
38	21988	8	LOCKWASHER 3/8"
39	21625	8	HEX NUT 3/8"
	JD72-7320 ONLY		
40	21630	4	CAPSCREW 3/8" X 1"
	JD74-7520 ONLY		
40A	21641	4	CAPSCREW 3/8" X 3 3/4"
40B	06430012	4	SPACER, 1x9/16x2 3/4
41	32724	2	FLATWASHER 10MM
42	27513	2	CAPSCREW 10MM X 25MM
43	06500001	1	HOSE 1/4" X 75"
44	06500002	1	HOSE 1/4" X 65"
**	34618	38"	HOSE SLEEVE (NOT SHOWN)

LIFT VALVE - JD72-7520 TWIN, 3SP, CAB (2004 UPDATE)

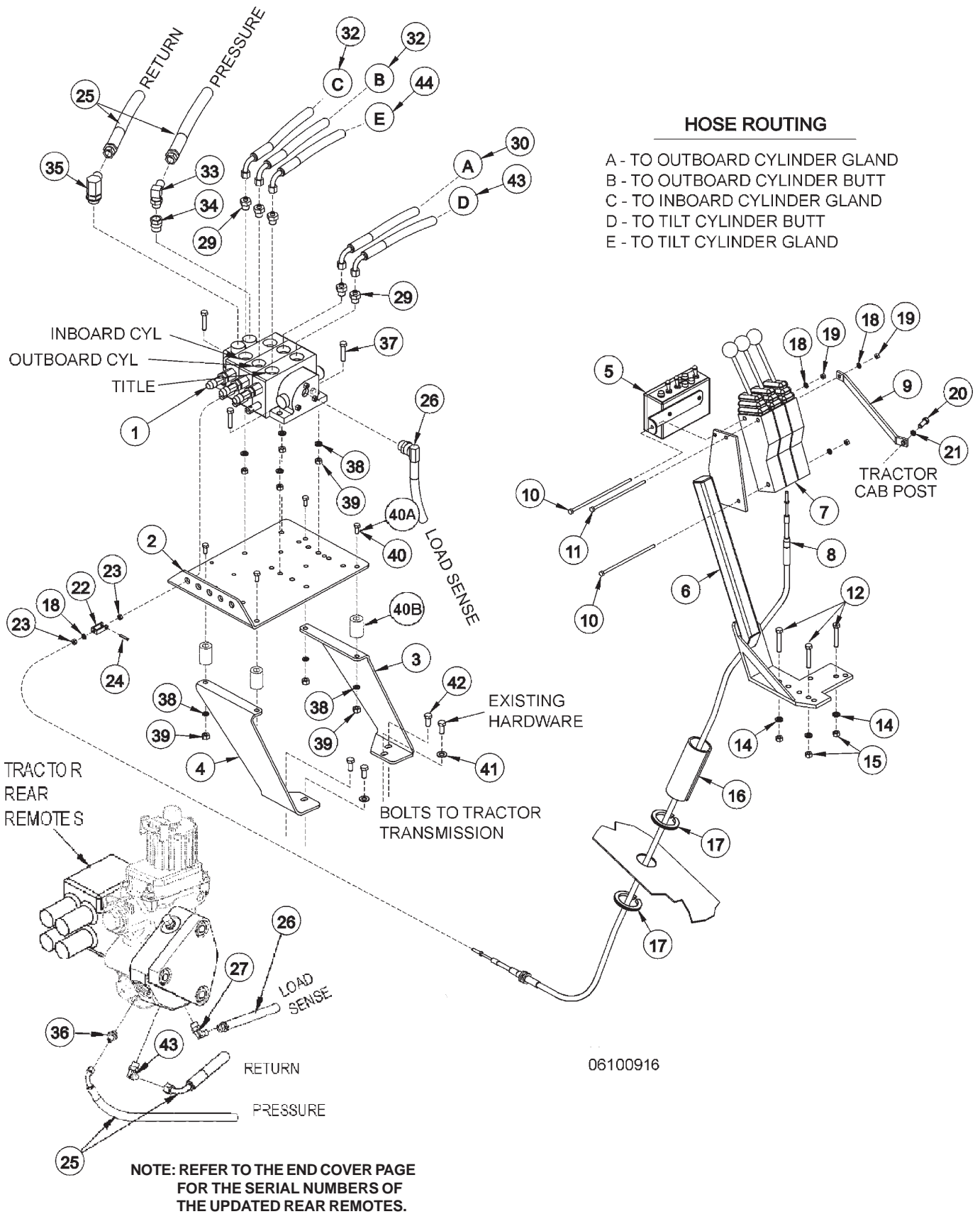

LIFT VALVE - JD72-7520 TWIN, 3SP, CAB (2004 UPDATE)

ITEM	PART NO.	QTY.	DESCRIPTION
1	31324	1	3 SPOOL VALVE HUSCO
2	34622	1	VALVE MOUNTING PLATE
3	34621	1	VALVE MOUNTING ANGLE, LF
4	34620	1	VALVE MOUNTING ANGLE, RF
5	34521	1	SWITCH BOX, TWIN
6	23865B	1	CABLE CONTROL MOUNTING BRACKET
7	6T1251	3	CABLE CONTROL BOX
8	34623	3	CONTROL CABLE 122"
9	30750A	1	SUPPORT BRACKET
10	22903	2	CAPSCREW 1/4" X 5-1/2
11	21545	1	CAPSCREW 1/4" X 6" NC
12	21635	3	CAPSCREW 3/8" X 2 1/4"
14	22016	3	FLATWASHER 3/8"
15	21627	3	NYLOCK NUT 3/8"
16	6T3200	2	SPLIT HOSE 6" LONG
17	28503	1	TRIM LOCK 9/16"
18	21986	7	LOCKWASHER 1/4"
19	21525	3	HEX NUT 1/4"
20	33534	1	CAPSCREW 10MM X 20MM (1.5 PITCH)
21	32691	1	LOCKWASHER 10MM
22	6T4411	3	CABLE CLEVIS
23	21500	6	HEX NUT 1/4" UNF
24	6T3017	3	ROLL PIN
25	34612	2	HOSE, 1/2" X 34" (PRESSURE & RETURN)
26	34968	1	HOSE 1/4" X 48" (LOAD SENSE)
27	06503013	1	ELBOW 14MM X 5/16"
29	32807	5	ADAPTER
30	06500000	1	HOSE, 1/4" X 131"
32	33364	2	HOSE, 1/4" X 120"
33	33382	1	ELBOW, 1/2"
34	32678	1	ADAPTER 5/8" x 1/2"
35	33383	1	ELBOW 5/8' x 1/2"
36	33463	1	ADAPTER 22 MM
37	21633	4	CAPSCREW 3/8" X 1 3/4"
38	21988	8	LOCKWASHER 3/8"
39	21625	8	HEX NUT 3/8"
JD72-7320 ONLY			
40	21630	4	CAPSCREW 3/8" X 1"
JD74-7520 ONLY			
40A	21641	4	CAPSCREW 3/8" X 3 3/4"
40B	06430012	4	SPACER, 1x9/16x2 3/4
41	32724	2	FLATWASHER 10MM
42	27513	2	CAPSCREW 10MM X 25MM
43	06503009	1	ELBOW 22MM X 1/2"
**	34618	38"	HOSE SLEEVE (NOT SHOWN)

LIFT VALVE - JD66-6715 TWIN, 3SP, CAB (ORIGINAL REMOTE)

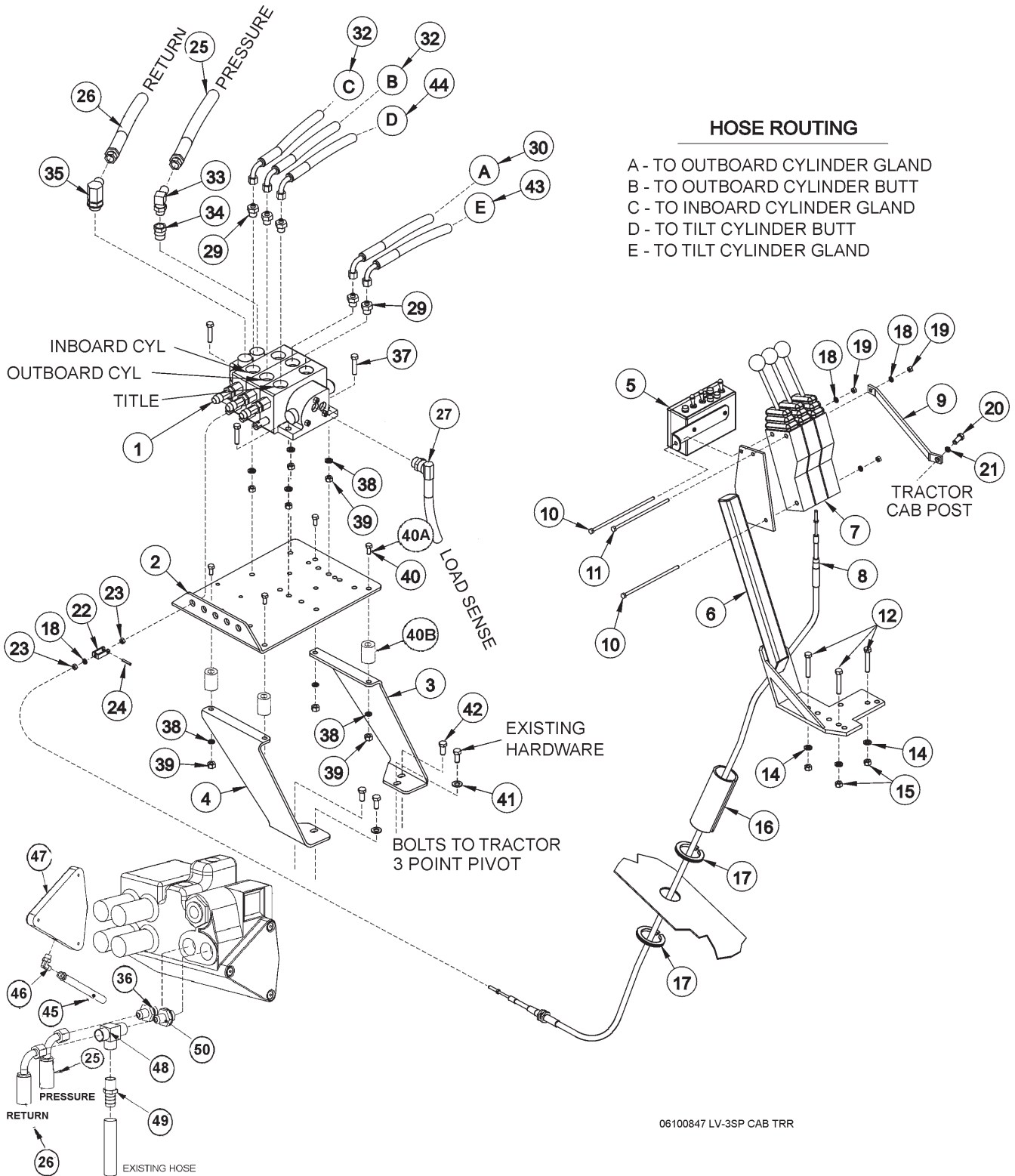

NOTE: REFER TO THE END COVER PAGE FOR THE SERIAL NUMBERS OF THE UPDATED REAR REMOTES.

LIFT VALVE - JD66-6715 TWIN, 3SP, CAB (ORIGINAL REMOTE)

ITEM	PART NO.	QTY.	DESCRIPTION
1	31324	1	3 SPOOL VALVE HUSCO
2	34622	1	VALVE MOUNTING PLATE
3	34621	1	VALVE MOUNTING ANGLE, LF
4	34620	1	VALVE MOUNTING ANGLE, RF
5	34521	1	SWITCH BOX, TWIN
6	23865B	1	CABLE CONTROL MOUNT BRAC
7	6T1251	3	CABLE CONTROL BOX
8	34623	3	CONTROL CABLE 122"
9	30750A	1	SUPPORT BRACKET
10	22903	2	CAPSCREW 1/4" X 5-1/2
11	21545	1	CAPSCREW 1/4" X 6" NC
12	21635	3	CAPSCREW 3/8" X 2 1/4"
14	22016	3	FLATWASHER 3/8"
15	21627	3	NYLOCK NUT 3/8"
16	6T3200	2	SPLIT HOSE 6" LONG
17	28053	1	TRIM LOCK 9/16"
18	21986	7	LOCKWASHER 1/4"
19	21525	3	HEX NUT 1/4"
20	33534	1	CAPSCREW 10MM X 20MM
21	32691	1	LOCKWASHER 10MM
22	6T4411	3	CABLE CLEVIS
23	21500	6	HEX NUT 1/4" UNF
24	6T3017	3	ROLL PIN
25	33488	2	HOSE, 1/2" X 25" (PRESSURE)
26	06500021	1	HOSE 1/2" X 27" (RETURN)
27	06500019	1	HOSE 1/4" X 48" (LOAD SENSE)
29	33271	5	ADAPTER 1/2" X 3/8
30	06500000	1	HOSE, 1/4" X 131"
32	33364	2	HOSE, 1/4" X 120"
33	33382	1	ELBOW 1/2" MORB X 1/2" MJ
34	32678	1	ADAPTER 5/8" MORB X 1/2" FORB
35	33383	1	ELBOW 5/8" MORB X 1/2" MJ
36	33463	1	ADAPTER 22 MM
37	21633	4	CAPSCREW 3/8" X 1 3/4"
38	21988	8	LOCKWASHER 3/8"
39	21625	8	HEX NUT 3/8"
	JD72-7320 ONLY		
40	21630	4	CAPSCREW 3/8" X 1"
	JD74-7520 ONLY		
40A	21641	4	CAPSCREW 3/8" X 3 3/4"
40B	06430012	4	SPACER, 1x9/16x2 3/4
41	32724	2	FLATWASHER 10MM
42	27513	2	CAPSCREW 10MM X 25MM
43	06500001	1	HOSE 1/4" X 75"
44	06500002	1	HOSE 1/4" X 65"
45	06500019	1	HOSE 1/4" X 48"
46	31739	1	ELBOW 5/16" X 12 MM
47	AL112432	1	END COVER
48	33948	1	TEE 5/8 "
49	33949	1	FEETING, BARB 5/8"
50	33680	1	ADAPTER 22MM X 5/8" MJ
**	34618	38"	HOSE SLEEVE (NOT SHOWN)

LIFT VALVE - JD66-6715 TWIN, 3SP, CAB (2004 UPDATE)

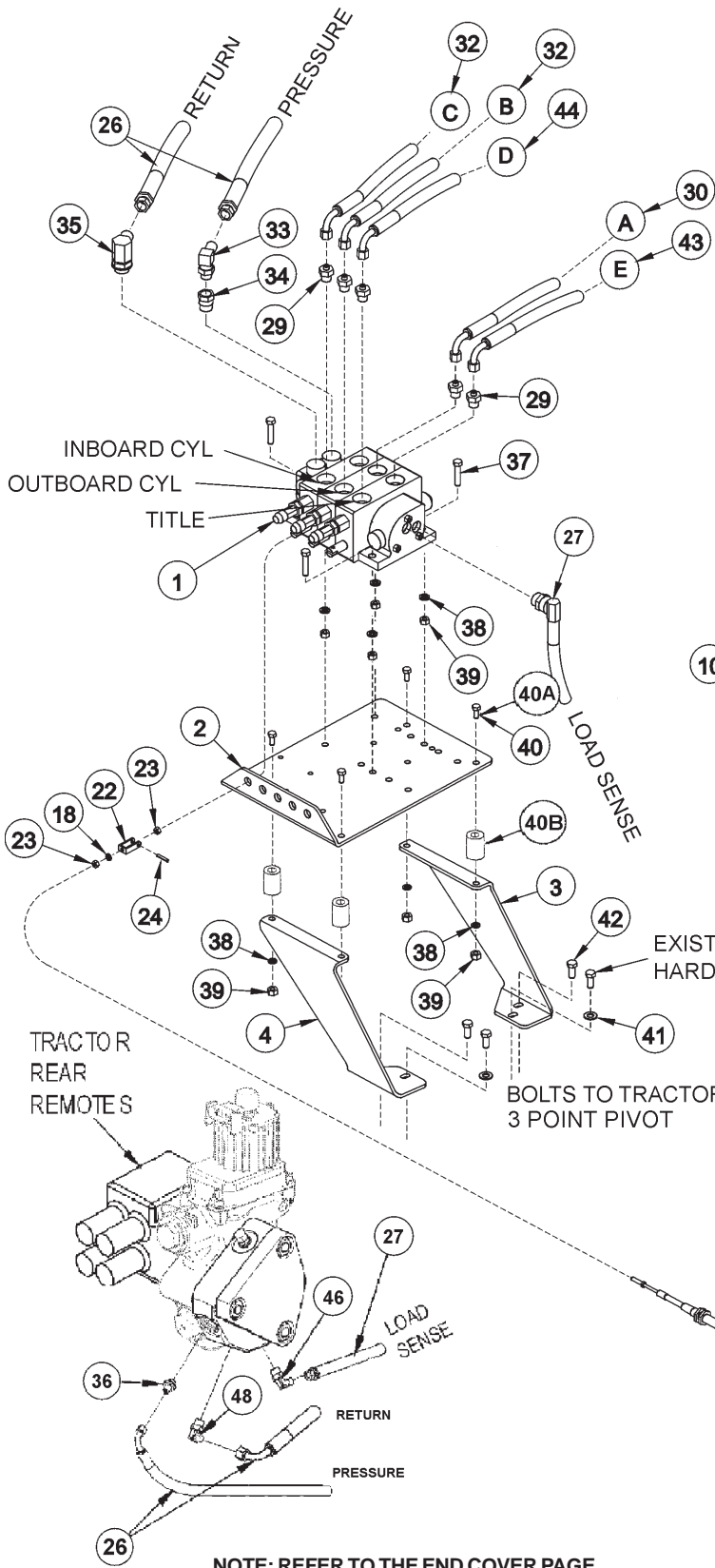

HOSE ROUTING

- A - TO OUTBOARD CYLINDER GLAND
- B - TO OUTBOARD CYLINDER BUTT
- C - TO INBOARD CYLINDER GLAND
- D - TO TILT CYLINDER BUTT
- E - TO TILT CYLINDER GLAND

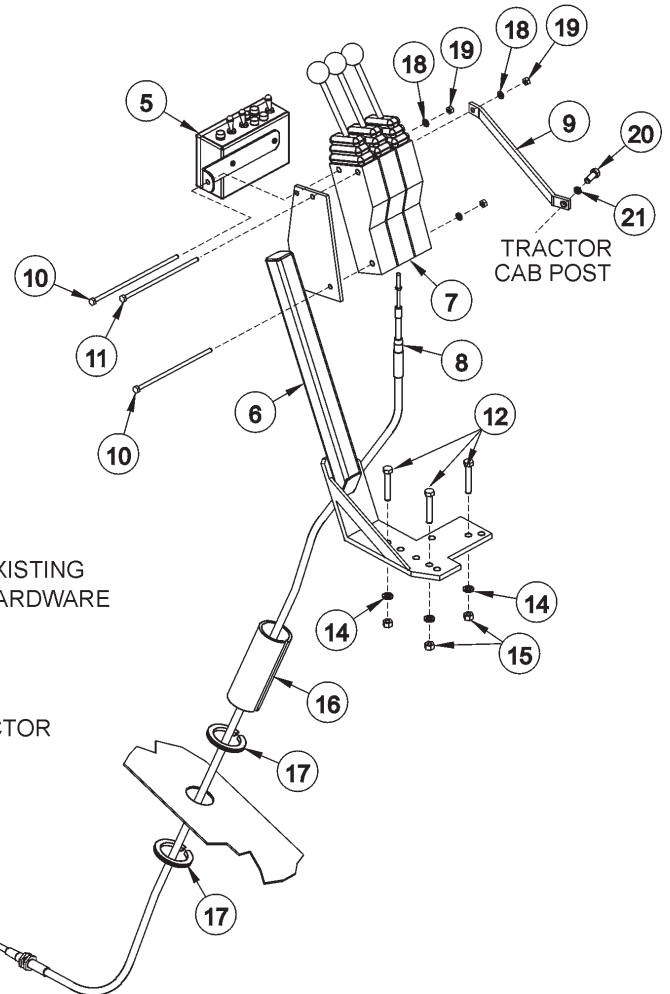

NOTE: REFER TO THE END COVER PAGE FOR THE SERIAL NUMBERS OF THE UPDATED REAR REMOTES.

06100847 LV-3SP CAB TRR

LIFT VALVE - JD66-6715 TWIN, 3SP, CAB (2004 UPDATE)

ITEM	PART NO.	QTY.	DESCRIPTION
1	31324	1	3 SPOOL VALVE HUSCO
2	34622	1	VALVE MOUNTING PLATE
3	34621	1	VALVE MOUNTING ANGLE, LF
4	34620	1	VALVE MOUNTING ANGLE, RF
5	34521	1	SWITCH BOX, TWIN
6	23865B	1	CABLE CONTROL MOUNT BRAC
7	6T1251	3	CABLE CONTROL BOX
8	34623	3	CONTROL CABLE 122"
9	30750A	1	SUPPORT BRACKET
10	22903	2	CAPSCREW 1/4" X 5-1/2
11	21545	1	CAPSCREW 1/4" X 6" NC
12	21635	3	CAPSCREW 3/8" X 2 1/4"
14	22016	3	FLATWASHER 3/8"
15	21627	3	NYLOCK NUT 3/8"
16	6T3200	2	SPLIT HOSE 6" LONG
17	28053	1	TRIM LOCK 9/16"
18	21986	7	LOCKWASHER 1/4"
19	21525	3	HEX NUT 1/4"
20	33534	1	CAPSCREW 10MM X 20MM
21	32691	1	LOCKWASHER 10MM
22	6T4411	3	CABLE CLEVIS
23	21500	6	HEX NUT 1/4" UNF
24	6T3017	3	ROLL PIN
26	34612	2	HOSE 1/2" X 34" (PRESSURE & RETURN)
27	06500019	1	HOSE 1/4" X 48" (LOAD SENSE)
29	33271	5	ADAPTER 1/2" X 3/8
30	06500000	1	HOSE, 1/4" X 131"
32	33364	2	HOSE, 1/4" X 120"
33	33382	1	ELBOW 1/2" MORB X 1/2" MJ
34	32678	1	ADAPTER 5/8" MORB X 1/2" FORB
35	33383	1	ELBOW 5/8" MORB X 1/2" MJ
36	33463	1	ADAPTER 22 MM
37	21633	4	CAPSCREW 3/8" X 1 3/4"
38	21988	8	LOCKWASHER 3/8"
39	21625	8	HEX NUT 3/8"
	JD72-7320 ONLY		
40	21630	4	CAPSCREW 3/8" X 1"
	JD74-7520 ONLY		
40A	21641	4	CAPSCREW 3/8" X 3 3/4"
40B	06430012	4	SPACER, 1x9/16x2 3/4
41	32724	2	FLATWASHER 10MM
42	27513	2	CAPSCREW 10MM X 25MM
43	06500001	1	HOSE 1/4" X 75"
44	06500002	1	HOSE 1/4" X 65"
45	06500019	1	HOSE 1/4" X 48"
46	06503013	1	ELBOW 14 MM X 5/16"
48	06503009	1	ELBOW 22 MM X 1/2"
**	34618	38"	HOSE SLEEVE (NOT SHOWN)

END COVER (2004 UPDATE)

JD6000 SERIES SERIAL #'S WITH THIS CHANGE: 391333, 391640, 392239, 395891, 396190, 397161, 396515, 396572, 396560, 396777, 396754, 396764, 396981, 397327, 396983, 396987, 397165, 397159, 397211, 397773, 397450, 397354, 397341, 397498, 397527, 397520, 397360, 397475, 397538, 397569, 397554, 397545, 397585, 397506, 397570, 397587, 397575, AND MODEL #'S STARTING WITH #398797.

JD7000 SERIES SERIAL #'S WITH THIS CHANGE START AT: 12451

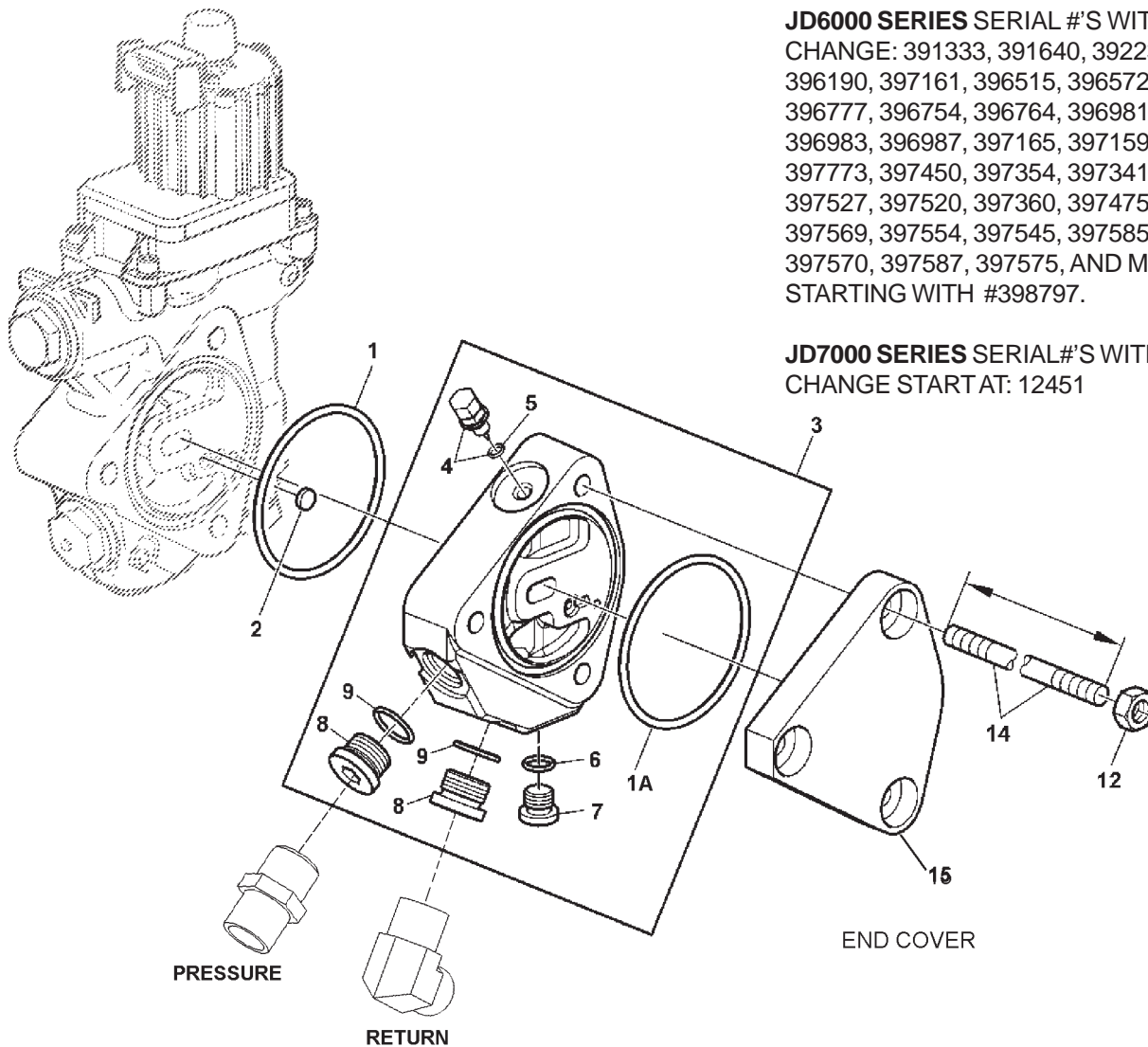

NOTE: ITEM # 1, 12 AND 15 ARE THE TRACTOR EXISTING HARDWARE .

ITEM	PART NO.	QTY.	DESCRIPTION
1	R95494	AVA	O-RING
2	R95493	AVA	DISK
3	AL161388	AVA	SPACER
4	AL117977	1	SCREW
5	51M7052	1	O-RING
6	51M7041	1	O-RING
7	15M7076	1	DRAIN PLUG
8	15M7077	2	DRAIN PLUG
9	51M7045	1	O-RING
12	14M7148	1	NUT
14	L169845	3	STUD

PUMP DRIVESHAFT ASSEMBLY

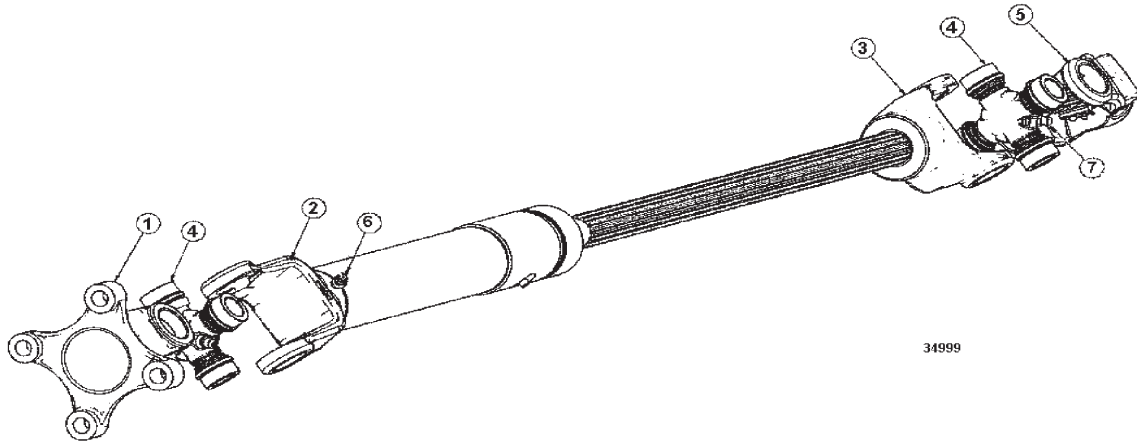

ITEM	PART NO.	QTY.	DESCRIPTION
*	34999	AVA	DRIVESHAFT,U-JOINT
1	06505004	1	YOKE PULLEY, 34999
2	06505005	1	SLEEVE, 34999
3	06505006	1	SHAFT, 34999
4	06505007	2	CROSS, 34999
5	06505008	1	YOKE DRIVE, 34999
6	6T3203	1	GREASE ZERK, 1/4 X 45
7	6T3207	3	GREASE ZERK, 1/4 X STR

HYDRAULIC COOLER - CAB - OLD

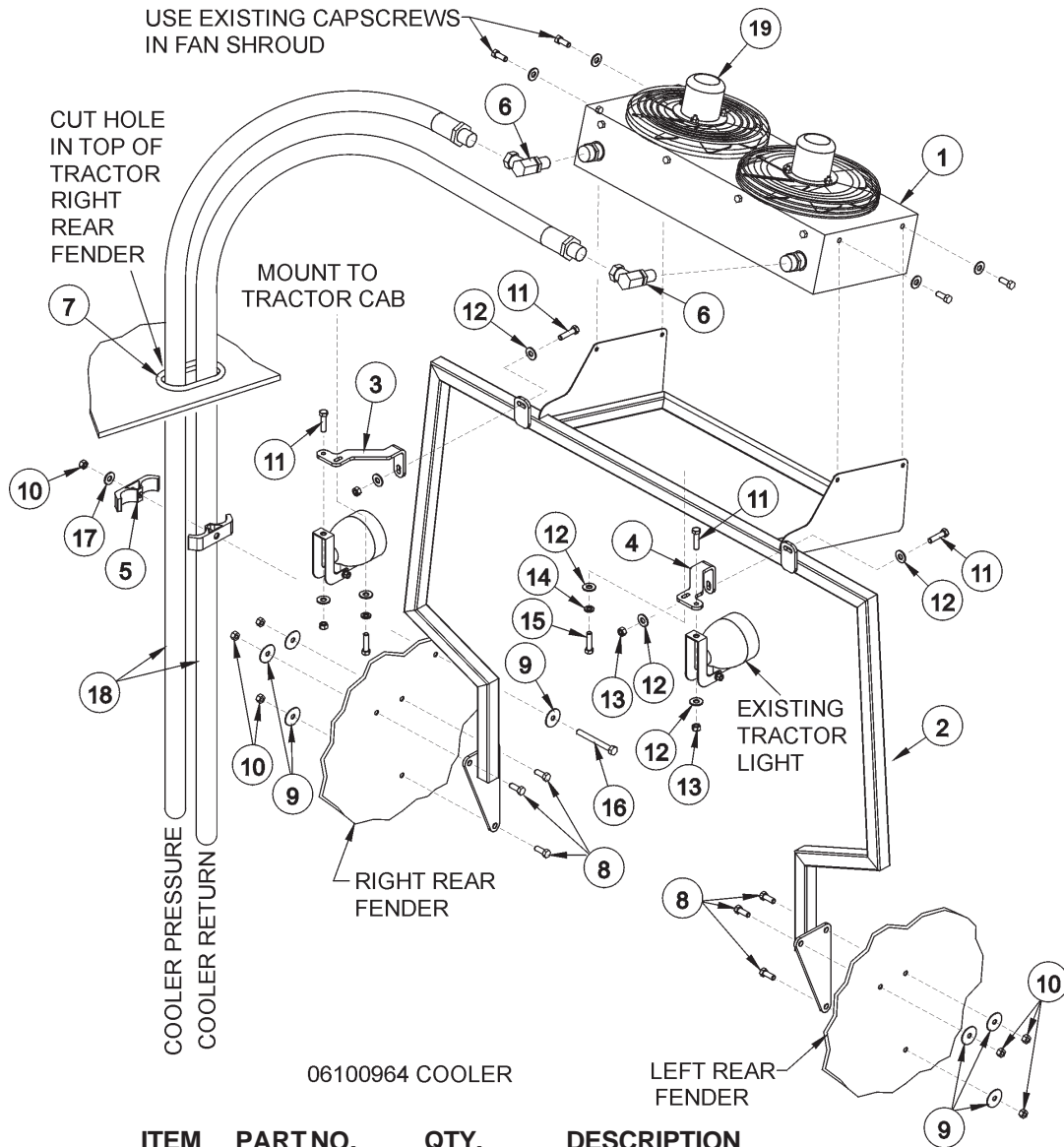

ITEM	PART NO.	QTY.	DESCRIPTION
1	34374	1	COOLER ASSY.
2	34628	1	COOLER STAND
3	34636	1	MOUNTING BRACKET RIGHT SIDE
4	34637	1	MOUNTING BRACKET LEFT SIDE
5	TB3031	1	CLAMP, DOUBLE TUBE 1 1/4"
6	33260	2	ELBOW 1" MJ X 1" MOR
7	TB3440	1	TRIM LOCK, 5/8 X 5/16 FNPBL
8	21630	6	CAPSCREW 3/8" X 1"
9	6T2615	7	FENDER WASHER 3/8"
10	21627	6	NYLOCK NUT 3/8"
11	21580	4	CAPSCREW 5/16" X 1"
12	22015	9	FLATWASHER 5/16"
13	21577	4	NYLOCK NUT 5/16"
14	21987	3	LOCKWASHER 5/16"
15	27508	2	CAPSCREW 8MM X 20MM
16	21587	1	CAPSCREW 5/16" X 2 3/4"
17	21575	1	HEX NUT 5/16"
18	*	REF.	REFER TO TRACTOR MOUNTING KIT - HYDRAULICS

HYDRAULIC COOLER - CAB 6420 - NEW

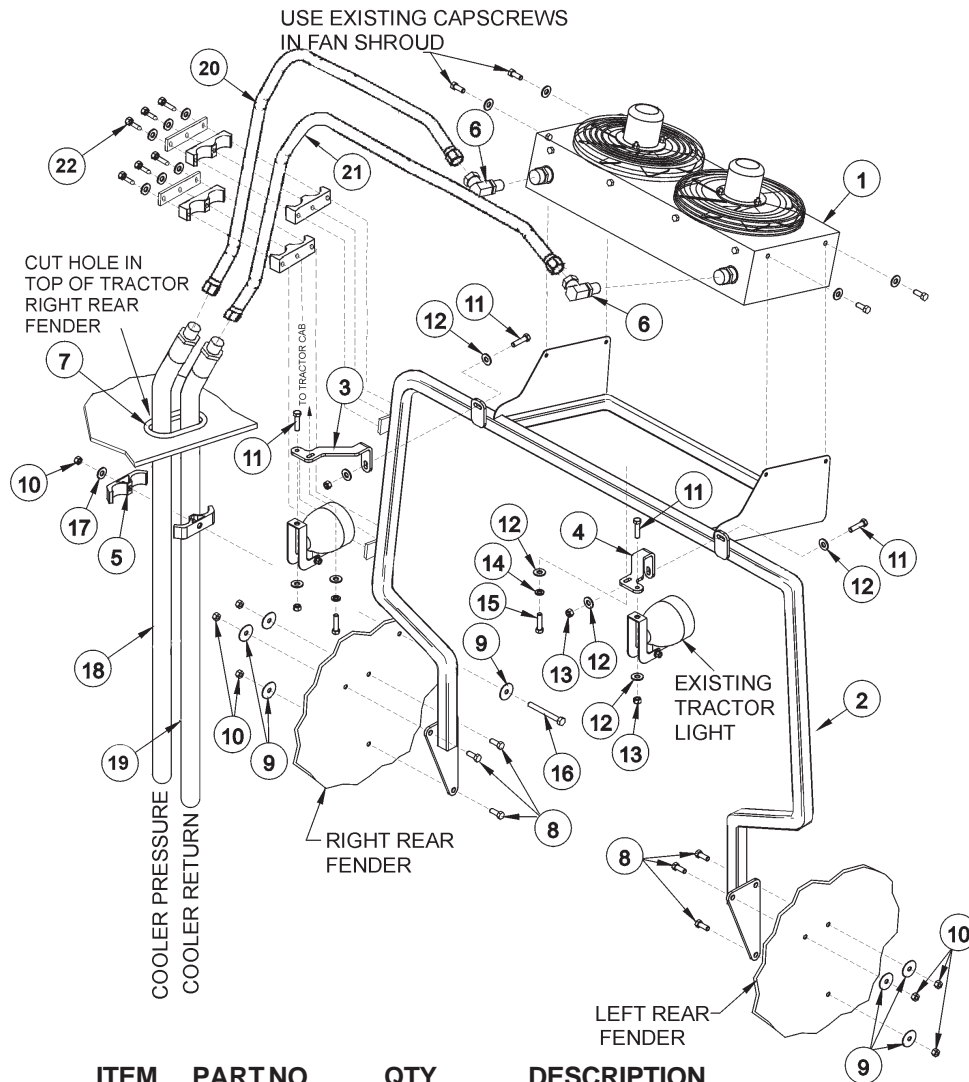

ITEM	PART NO.	QTY.	DESCRIPTION
1	34374	1	COOLER ASSY.
2	34628	1	COOLER STAND
3	34636	1	MOUNTING BRACKET RIGHT SIDE
4	34637	1	MOUNTING BRACKET LEFT SIDE
5	TB3031	1	CLAMP, DOUBLE TUBE 1 1/4"
6	33260	2	ELBOW 1" MJ X 1" MOR
7	TB3440	12"	TRIMLOCK
8	21630	6	CAPSCREW 3/8" X 1"
9	6T2615	7	FENDER WASHER 3/8"
10	21627	6	NYLOCK NUT 3/8"
11	21580	4	CAPSCREW 5/16" X 1"
12	22015	9	FLATWASHER 5/16"
13	21577	4	NYLOCK NUT 5/16"
14	21987	3	LOCKWASHER 5/16"
15	27508	2	CAPSCREW 8MM X 20MM
16	21587	1	CAPSCREW 5/16" X 2 3/4"
17	21575	1	HEX NUT 5/16"
18	*	REF.	REFER TO TRACTOR MOUNTING KIT - HYDRAULICS
19	*	REF.	REFER TO TRACTOR MOUNTING KIT - HYDRAULICS
20	06506010	1	PREFORMED TUBE
21	06506009	1	PREFORMED TUBE
22	06505014	2	CLAMP KIT

SOLENOID BRAKE VALVE ASSEMBLY

NOTE:

CAUTION - TORQUE COIL NUT TO 5 Ft. Lbs. MAXIMUM. DO NOT OVER TORQUE NUT, DAMAGE TO CARTRIDGE OR COIL WILL OCCUR.

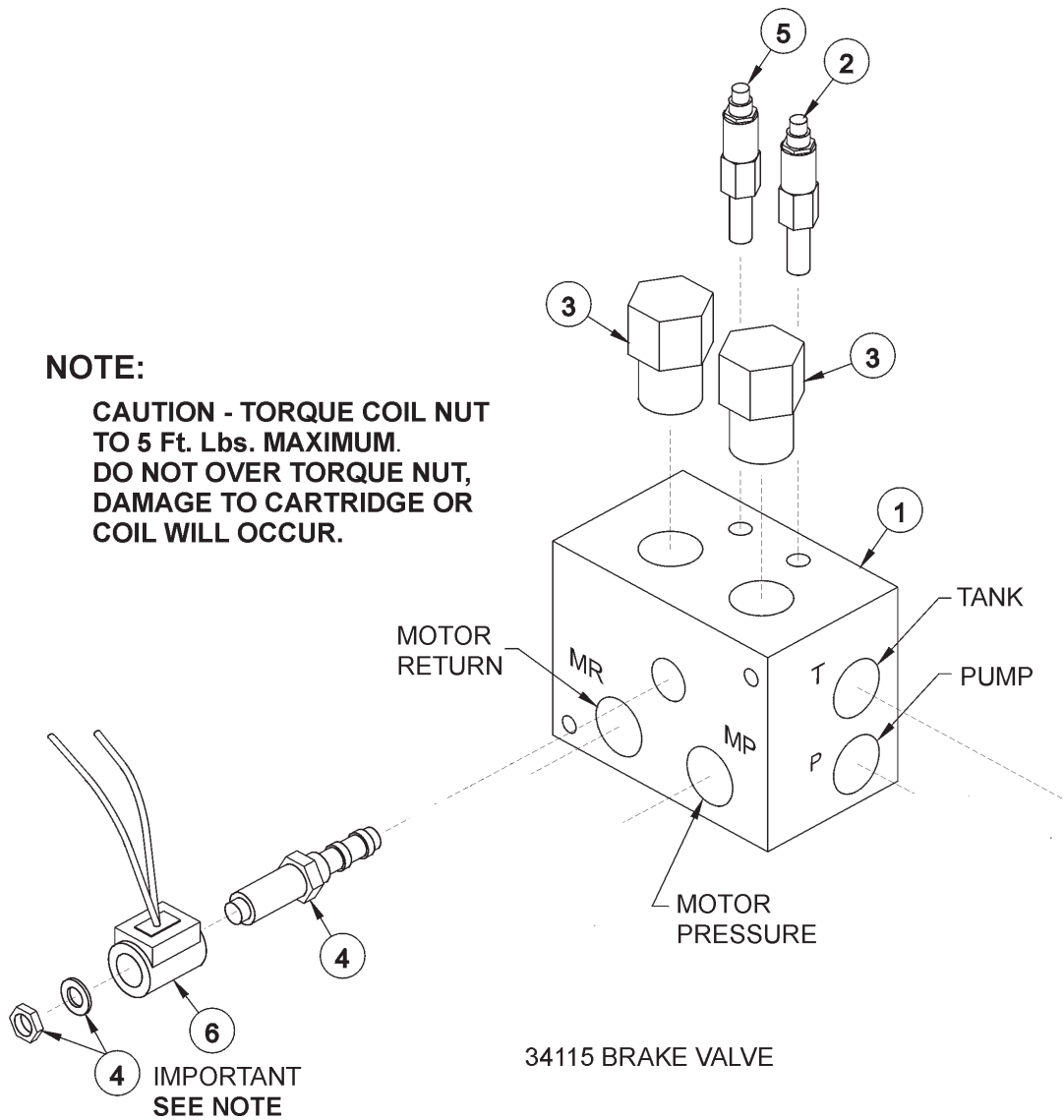

ITEM	PARTNO.	QTY.	DESCRIPTION
*	34115	AVAIL	SOLENOID BRAKE VALVE ASSEMBLY - HIGH PRESSURE
1	34092	1	BRAKE VALVE, BLANK
2	34095	1	RELIEF VALVE, 3000 PSI
3	34094	2	LOGICELEMENT
4	34093	1	CARTRIDGE, 2 POSITION, 3 WAY (WITH NUT & WASHER)
5	34091	1	RELIEF VALVE, 2600 PSI
6	34689	1	COIL, 12 VDC, BRAKE VALVE
**	34096	2	RELIEF SEAL KIT
**	34097	1	SOLENOID SEALKIT
**	34098	2	ELEMENT SEAL KIT

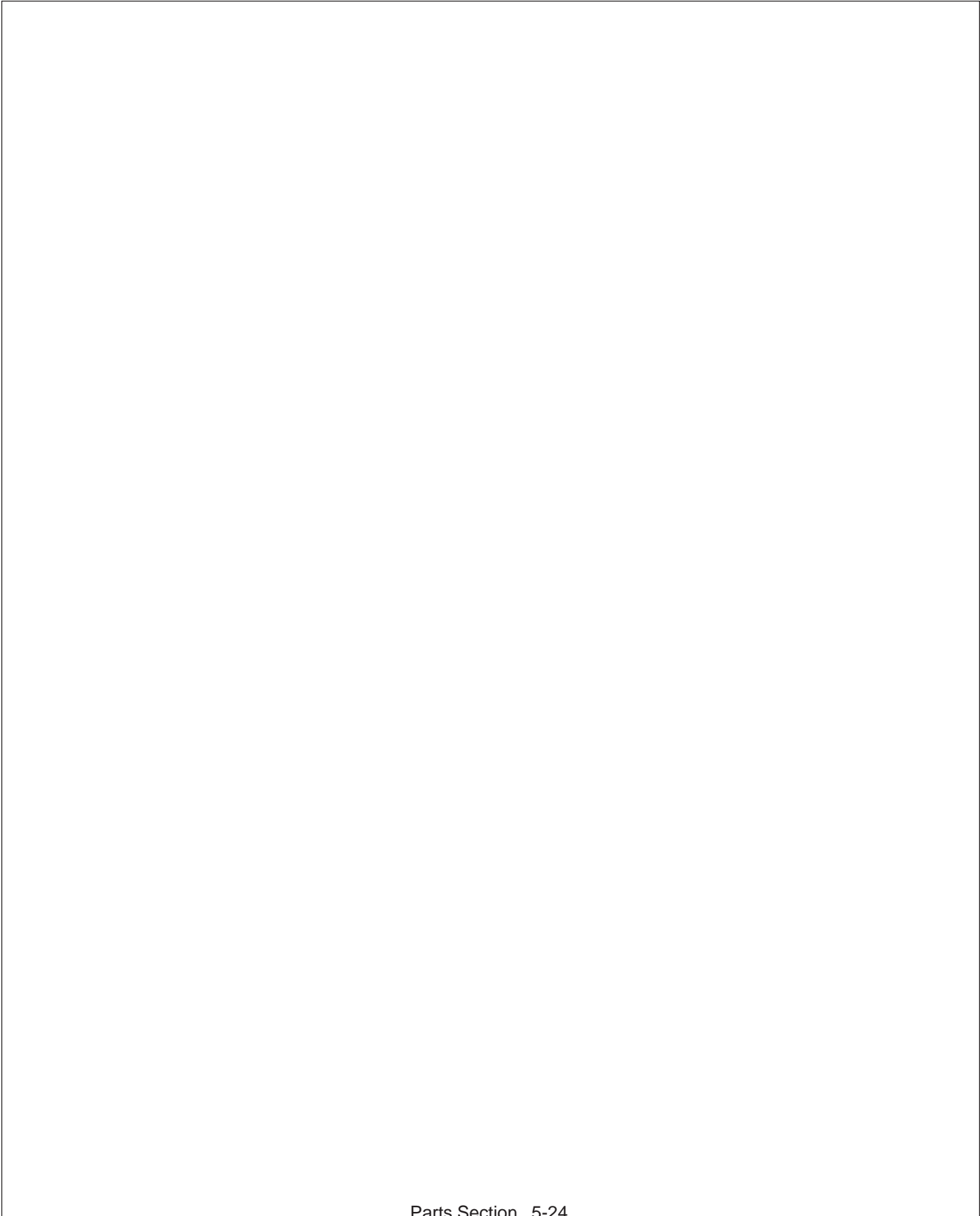

TWIN ROTARY COMMON SECTION

**COMMON
PARTS
SECTION**

TABLE OF CONTENTS

SECTION	ASSEMBLY	PAGE
REAR ROTARY DECK ASSEMBLY		6-4
TRAILKAT® REAR ROTARY DECK ASSY		6-6
REAR RTRY CASTER WHEEL & 3PT ASSEMBLY		6-8
REAR ROTARY HYDRAULICS		6-10
ROTARY MOTORS		6-12
TWIN PUMP		6-14
HUSCO VALVES		6-16
COOLER ASSEMBLY		6-24
SAFETY STAND		6-26
CASTER WHEEL ASSEMBLY		6-27
BRAKE VALVE WITH METRIPAK		6-28
SWITCHBOX SCHEMATIC		6-29

PARTS ORDERING GUIDE

The following instructions are offered to help eliminate needless delay and error in processing purchase orders for the equipment in this manual.

1. The Parts Section is prepared in logical sequence and grouping of parts that belong to the basic machine featured in this manual. Part Numbers and Descriptions are given to help locate the parts and quantities required.

2. The Purchase Order must indicate the **Name and Address** of the person or organization ordering the parts, **who should be charged**, and if possible, the **serial number of the machine** for which the parts are being ordered.

3. The purchase order must clearly list the **quantity of each part**, the complete and correct **part number**, and the basic **name of the part**.

4. The manufacturer reserves the right to substitute parts where applicable.

5. Some parts may be unlisted items which are special production items not normally stocked and are subject to special handling. Request a quotation for such parts before sending a purchase order.

6. The manufacturer reserves the right to change prices without prior notice.

NOTE: When ordering replacement decals, refer to the part numbers and descriptions listed in the safety section in the front of this manual.



1000

For maximum safety and to guarantee optimum product reliability, always use genuine **Tiger** replacement parts. The use of inferior replacement parts may cause premature or catastrophic failure which could result in serious injury or death.

Direct any questions regarding parts to:

Tiger Corporation
3301 N. Louise Ave.
Sioux Falls, SD 57107
1-800-843-6849
1-605-336-7900

REAR ROTARY DECK ASSEMBLY

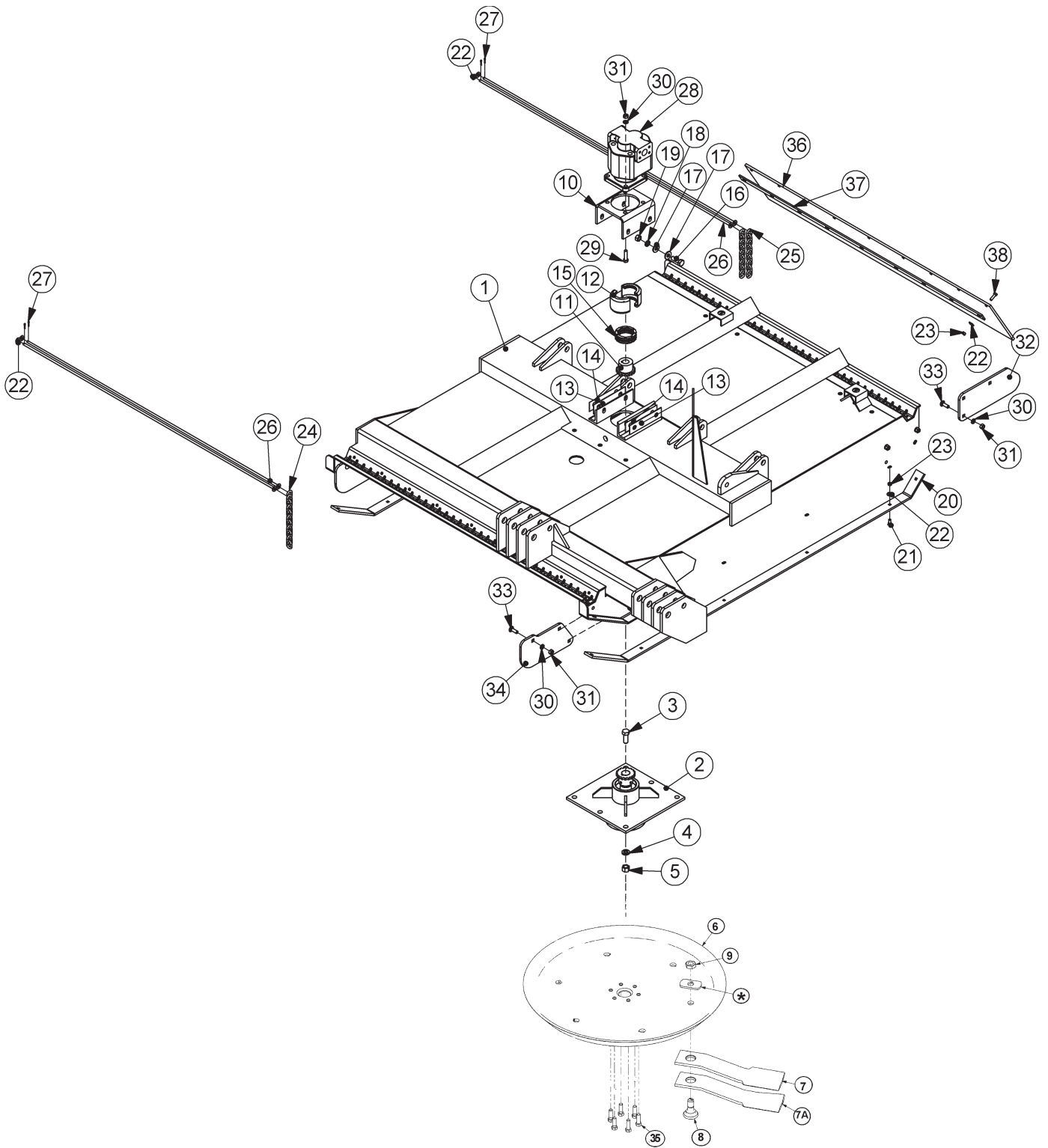

REAR ROTARY DECK ASSEMBLY

ITEM	PART NO.	QTY.	DESCRIPTION
**	23003	REF.	REAR RTRY, 60" W/REAR CHAINS
1	32616	1	RTRY, 60" DECK, TRR
2	6T1024H5	1	SPINDLE ASSY,CPLT,HD,5/8 HOLES
3	6T2277	6	CAPSCREW, 3/4" x 2" NF
4	21993	6	LOCKWASHER,3/4",GR 8
5	6T2413	6	HEX NUT,3/4,NF,GR 8
6	SEE DISK AND KNIVES ASSEMBLY PAGE		
*	SEE DISK AND KNIVES ASSEMBLY PAGE		
7	SEE DISK AND KNIVES ASSEMBLY PAGE		
7A	SEE DISK AND KNIVES ASSEMBLY PAGE		
8	SEE DISK AND KNIVES ASSEMBLY PAGE		
9	SEE DISK AND KNIVES ASSEMBLY PAGE		
10	6T1001	1	BRKT, MOTOR MTG, 60"SIDE RTRY
11	21223	1	SPROKET, 1-1/4" BORE
12	6T1033	1	COVER, COUPLING
13	6T0822	2	SHIM, MOTOR MOUNT, 14GA. (AS NEEDED)
14	6T0822A	2	SHIM, MOTOR MOUNT, 18 GA. (AS NEEDED)
15	6T1029	1	CHAIN, COUPLING
16	21783	4	CAPSCREW, 5/8 x 2,NC
17	25270	8	FLATWASHER,5/8", GR 8
18	21992	10	LOCKWASHER, 5/8
19	21775	4	HEX NUT, 5/8
20	23160A	2	SKID SHOE
21	6T2270	12	PLOW BOLT,3/8" X 1" NC
+22	22016	21	FLATWASHER,3/8"
+23	21625	21	HEX NUT,3/8",NC
+24	22993	71	CHAIN, 5/16" GR30, 9 LINK
+25	22992	71	CHAIN, 5/16" GR30, 10 LINK
+26	22054	4	ROD, CHAIN HOLDER
+27	6T3028	4	COTTER PIN, 1/8" x 1"
28	06504010	1	CURRENT MOTOR, (M365 - 2" GEAR)
	22680	1	ORIGINAL MOTOR, (M365 - 2" GEAR)
29	21733	4	CAPSCREW, 1/2 x 2,NC
30	21990	16	LOCKWASHER, 1/2"
31	21725	16	HEX NUT, 1/2" NC
32	33656	2	PLATE, GUARD, SAFETY, REAR, RTRY
33	6T2267	12	CARRIAGE BOLT, 1/2" x 2" NF, GR8
34	33655	2	PLATE, GAURD, SAFETY, FRONT, RTRY
35	6T2290	6	CAPSCREW,5/8x2,NF GR 8
36	24347	1	REAR DEFLECTOR FLAP
37	24349	1	FLAP MOUNTING BAR
38	21631	9	CAPSCREW, 3/8" x 1-1/4" NC

+ REAR CHAIN GAURDS ARE OPTIONAL, QUANTITIES MAY VARY

TRAILKAT® REAR ROTARY DECK ASSY

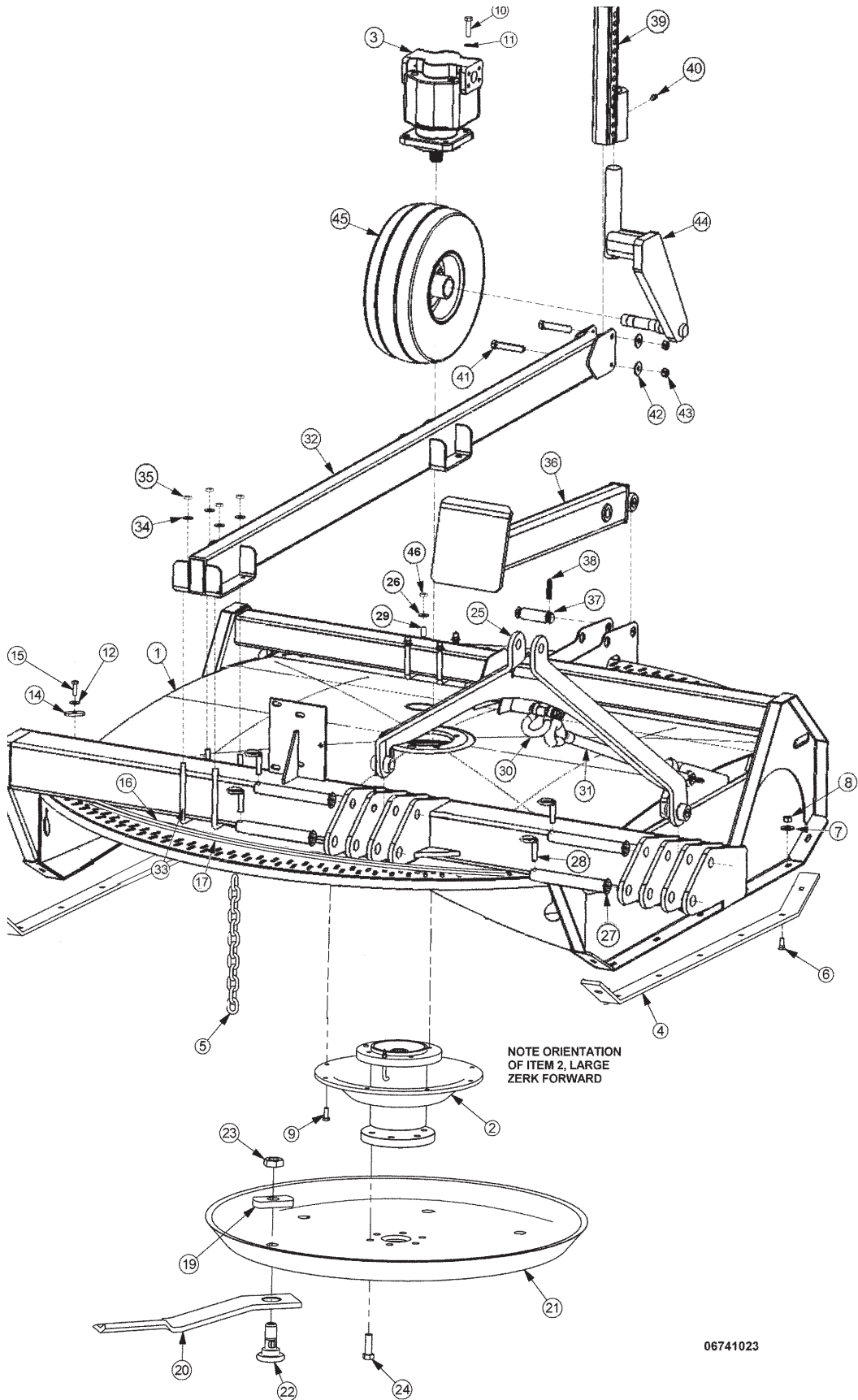

NOTE ORIENTATION
OF ITEM 2, LARGE
ZERK FORWARD

06741023

TRAILKAT® REAR ROTARY DECK ASSY

ITEM	PART NO.	QTY.	DESCRIPTION
1	06320002	1	TRAILKAT®,60,WLDMNT
2	34980	1	SPINDLE ASSY, TM 60"
3	06504016	1	CURRENT MOTOR,(M365-1 1/4" 14-SPLINE)
	34981	1	ORIGINAL MOTOR,(M365-1 1/4" 14-SPLINE)
4	34983	2	SKID,OUTBOARD, TM60
5	22992	156	CHAIN,10 LINK
6	6T2270	14	PLOW BOLT,3/8" X 1" NC
7	21988	14	FLATWASHER,3/8"
8	21625	27	HEX NUT,3/8",NC
9	21605	8	CAPSCREW, 3/8 x 1,NF GR 8
10	6T1025	4	CAPSCREW, 1/2 x 2,GR 8,NC
11	21990	4	LOCKWASHER, 1/2"
12	21988	7	FLATWASHER,3/8"
13	6T2283	7	CARRIAGE BOLT,3/8" X 1"NC
14	34972	4	PLATE,CAP,CHAIN
15	21631	4	CAPSCREW, 3/8 x 1-1/4,NC
16	34974	2	ROD,CHAIN,INNER, TM60
17	34973	2	ROD,CHAIN,OUTER, TM60
18	-		
19	SEE ROTARY KNIVES AND DISKS PAGE		
20	SEE ROTARY KNIVES AND DISKS PAGE		
21	SEE ROTARY KNIVES AND DISKS PAGE		
22	SEE ROTARY KNIVES AND DISKS PAGE		
23	SEE ROTARY KNIVES AND DISKS PAGE		
24	6T2290	6	CAPSCREW,5/8x2,NF GR 8
26	21990	4	LOCKWASHER,1/2
25	06370006	1	YOKE,3PNT,TRAILKAT®
27	42394	4	PIN,1 X 9 W/HOLE
28	TF1143	4	PIN,LYNCH 7/16 X 2
29	06420004	4	U-BOLT,3.25x4.50x.38,16NC,GR8
30	6T0112	2	SHACKLE,W/PIN,CPLT
31	22051	1	CABLE,LIFT,TRR,60
32	0637004	1	CASTER MNT,TRAILKAT®
33	06420005	4	U-BOLT,5.63x6.31x3/8,16NC,GR8
34	21988	4	LOCKWASHER,3/8
35	21625	4	HEX NUT,3/8 NC
36	28511	1	STAND,TRR SAFTY SUPPORT W/PAD
37	TB1033D	2	PIN,CLEVIS 1X 4(DRILLED 1/4)
38	6T3014	4	ROLLPIN,1/4 X 2
39	06370003	1	CASTER ADJ,TRAILKAT®
40	6T3211	1	GREASE ZERK,1/8 X STR
41	21738	2	CAPSCREW,1/2 X 3 1/4 NC
42	22018	2	FLATWASHER,1/2,WIDE
43	21725	2	HEX NUT,1/2 NC
44	22057	1	SPINDLE, CASTER AXLE, ASSY
45	23329	1	CASTER WHL,SOLID TIRE W/SPIND
46	21700	4	HEX NUT,1/2 NF

REAR ROTARY CASTER WHEEL & 3PT ASSEMBLY

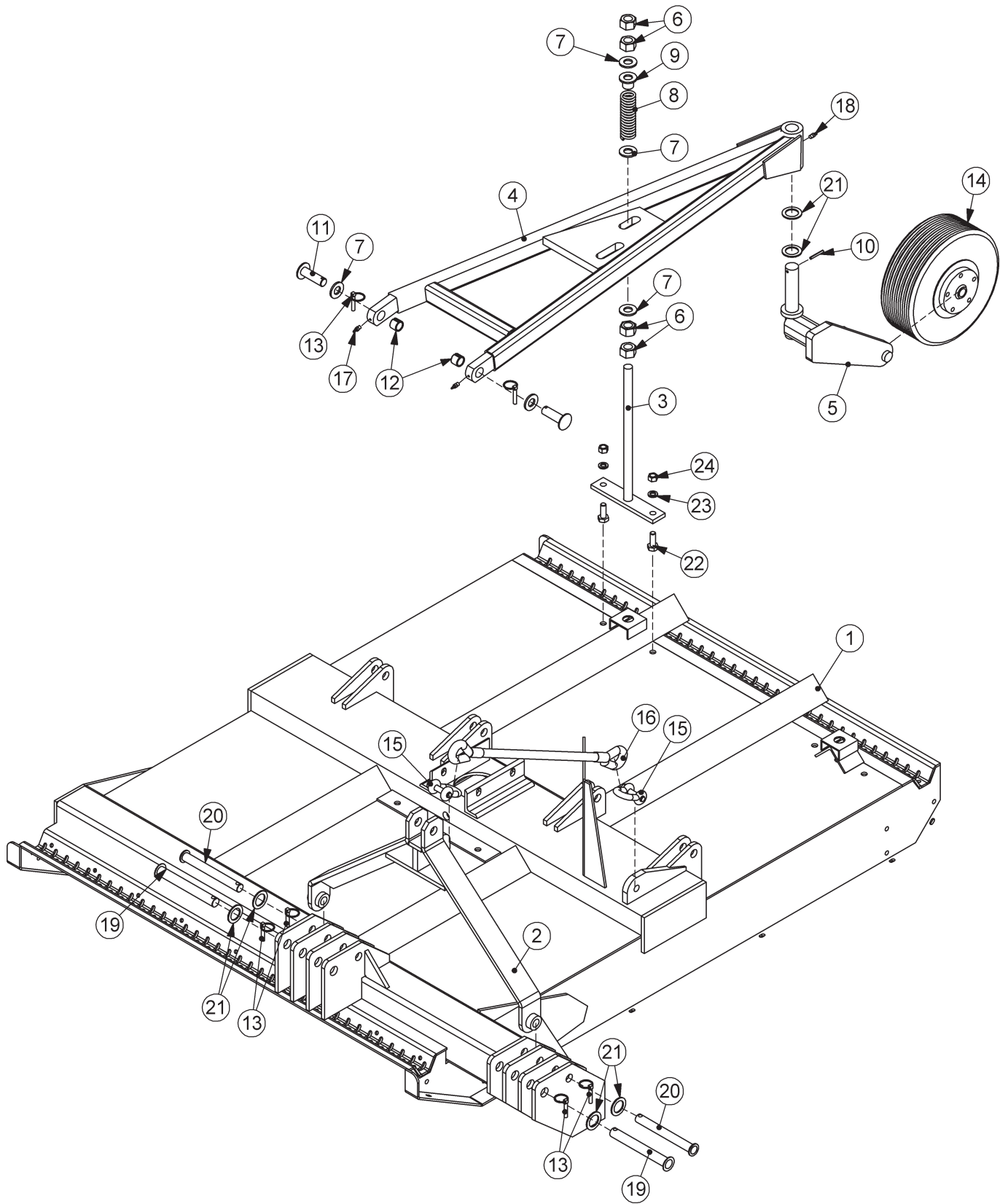

23003 3PT & CASTER

Twin Rotary Common Section 6-8

REAR ROTARY CASTER WHEEL & 3PT ASSEMBLY

ITEM	PART NO.	QTY.	DESCRIPTION
1	32616	1	RTRY, 60" DECK, TRR
2	21474A	1	HITCH, 3PT, TRR
3	22059B	1	ADJ ROD, TRR
4	25095A	1	FRAME, CASTER WHEEL, TRR 60"
5	22057	1	SPINDLE, CASTER AXLE, ASSY
6	21925	4	HEX NUT, 1" NC
7	22023	5	FLATWASHER, 1"
8	22058	1	SPRING, REAR RTRY
9	22753	1	TUBE, PROTECTOR
10	6T3014	1	ROLL PIN, 1/4" x 2"
11	22060	2	CASTER FRAME PIN
12	TB3010	2	BUSHING, 1"
13	TF1143	6	PIN, LYNCH, 7/16" x 2"
14	28548	1	CASTER WHEEL, SOLID TIRE
**	22065	1	HUB ASSY, REAR ROTARY
**	22066	1	HUB, CASTER (REAR ROTARY)
**	22070	1	DUST CAP
**	22071	5	HUB STUD
**	22073	1	HEX NUT, 1"NF (SLOTTED)
**	22533	1	COTTER PIN, 3/16" x 2"
**	6T0830	2	BEARING, CONE, CASTER WHEEL
**	6T0838	1	SEAL
**	23329	1	WHEEL, CPLT, SOLID TIRE
**	21416	1	TIRE, SOLID, RR-RTRY
**	22697	1	RIM, OUTER/RR RTRY CASTER
**	22696	1	RIM, REAR ROTARY CASTER
15	6T0112	2	SHACKLE, W/PIN, CPLT
16	22051	1	CABLE, LIFT, TRR, 60"
17	6T3207	2	GREASE ZERK, 1/4" X STR
18	6T3211	1	GREASE ZERK, 1/8" X STR
19	33698	2	PIN, CAPPED, 1-1/8" x 9"
20	33699	2	PIN, CAPPED, 1" x 9"
21	6T2617	6	BUSHING, MACH, 1-1/2IDX 2-1/4OD
22	21782	2	CAPSCREW, 5/8 x 1 3/4, NC
23	21992	2	LOCKWASHER, 5/8
	24	21775	2 HEX NUT, 5/8

** - NOT SHOWN

REAR ROTARY HYDRAULICS

ITEM	PART NO.	QTY.	DESCRIPTION
1	23003	1	REAR RTRY, 60"W/REAR CHAINS
1	30806	1	RTRY, 60" CPLT - HP (W/FBAR) TRR
2	06510083	1	VALVE,BRAKE,SOL,3000PSI,METRI
3	33555	4	ADAPTER,1MORB x 1MJIC
4	TF4852	2	KIT, FLANGE, #20
5	34198	1	HOSE, 1" x 40" (1FJX x 20FLG90)
6	34197	1	HOSE, 1" x 33" (1FJX x 20FLG90)
7	21644	2	CAPSCREW,3/8" X 5" NC
8	21625	2	HEX NUT,3/8",NC
9	22016	2	FLATWASHER,3/8"
10	21988	1	LOCKWASHER, 3/8"
11	6T2665	1	STAR LOCKWASHER, 3/8"
12	34192	1	HOSE, 1" x 185" (1MP x 1FJX45)
13	34193	1	HOSE, 1" x 65" (1FJX45 x 1FJX45)
14	33930	1	HOSE SLEEVE, TRR
15	6T1823	2	ZIP TIE, 14" STRAPS

60" ROTARY MOTOR

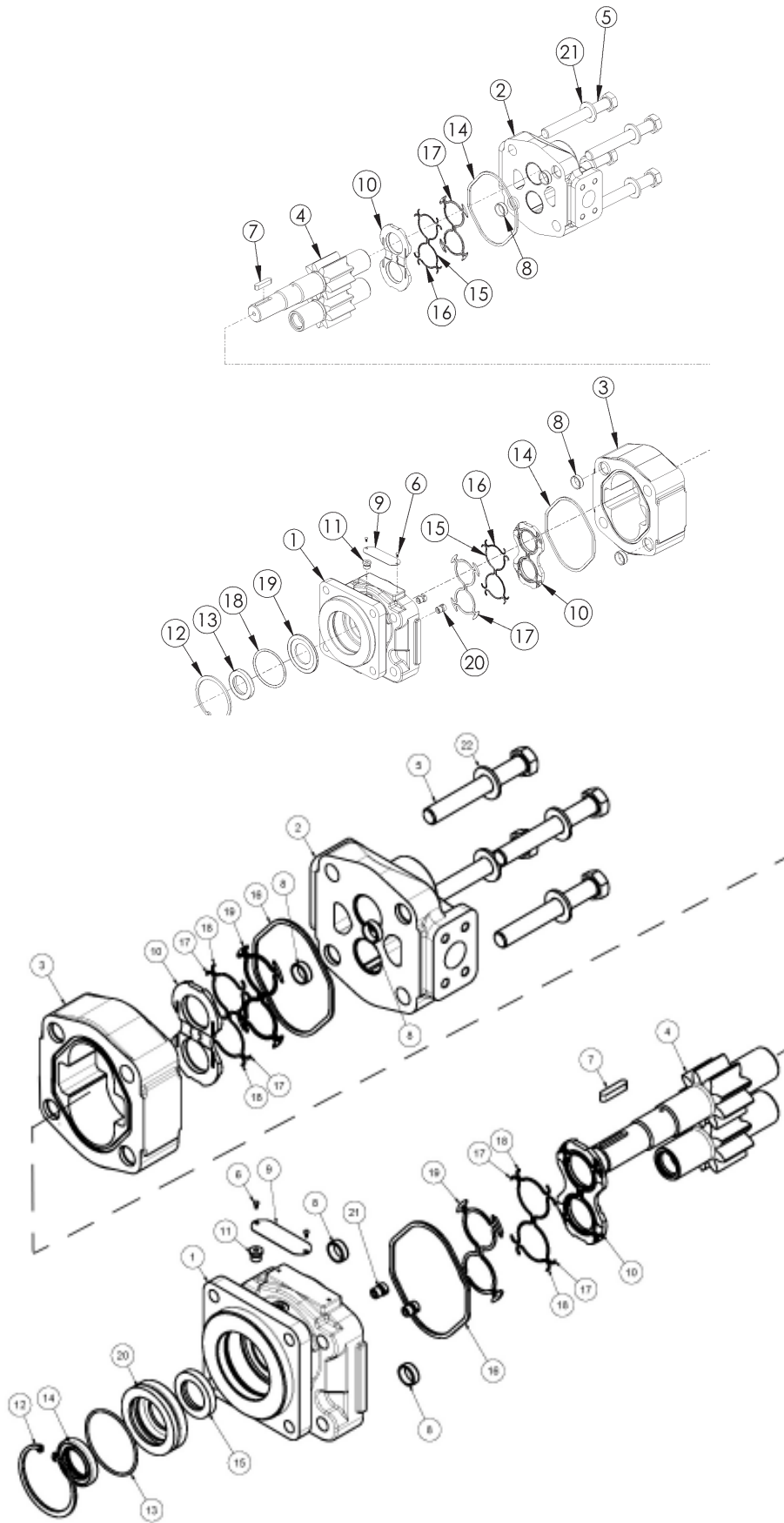

60" ROTARY MOTOR

ITEM	PART NO.	QTY.	DESCRIPTION
*	06504016	AVAIL	MOTOR ASSEMBLY 1 1/4" COMPLETE TSR/TRAILKAT
1	22790	1	SHAFT END COVER
2	06504025	1	PORT END COVER
3	02962194	1	GEAR HOUSING
4	06504053	1	MATCHED GEAR SET
5	02962197	4	CAP SCREW
6	06504027	2	SET SCREW
7	06504028	1	KEY
8	02962201	4	DOWEL PIN
9		1	NAMEPLATE
10	06504029	2	THRUSTPLATE
11	02961940	1	HEX PLUG
12	6T5200	1	SNAP RING
13	06504030	1	LIP SEAL (INCLUDED IN SEAL KIT)
14	22797	2	GASKET SEAL (INCLUDED IN SEAL KIT)
15	06504031	4	SIDE SEAL (INCLUDED IN SEAL KIT)
16	06504032	4	END SEAL (INCLUDED IN SEAL KIT)
17	06504033	2	BACK-UP SEAL (INCLUDED IN SEAL KIT)
18	06504034	1	SPACER
19	06504035	1	SEAL RETAINER
20	22791	2	CHECK ASSEMBLY
21	06504036	4	WASHER
*	06504023	AVAIL	SEAL KIT (INCLUDES 13, 14, 15, 16 AND 17)

ITEM	PART NO.	QTY.	DESCRIPTION
*	06504011	AVAIL	MOTOR ASSEMBLY 2 1/4" COMPLETE TRB60
	06504103	1	SEAL KIT
1	22790	1	HOUSING, SEC
2	06504088	1	HOUSING, PEC
3	06504062	1	HOUSING, GEAR
4	06504090	1	SET, GEAR SHAFT
5	06504104	4	CAP SCREW
6	06504078	2	SCREW, DRIVE
7	06504092	1	KEY
8	06504093	4	PIN, DOWEL
9	06504094	1	NAME PLATE
10	06504095	2	THRPL
11	02961940	1	PLUG, ODT
12	02962200	1	RING, SNAP
13	06504096	1	ORING
14	6T5101	1	SEAL, LIP
15	06504097	1	SEAL, LIP
16	22797	2	SEAL, SQ-R
17	06504098	4	SEAL, SIDE CHAN
18	06504099	4	SEAL, END CHAN
19	06504100	2	SEAL, BK-UP
20	06504101	1	RTNR, SEAL
21	6T5809	2	CHECK ASS'Y
22	06504102	4	WASHER

PUMP - SERVICE PARTS (06504002)

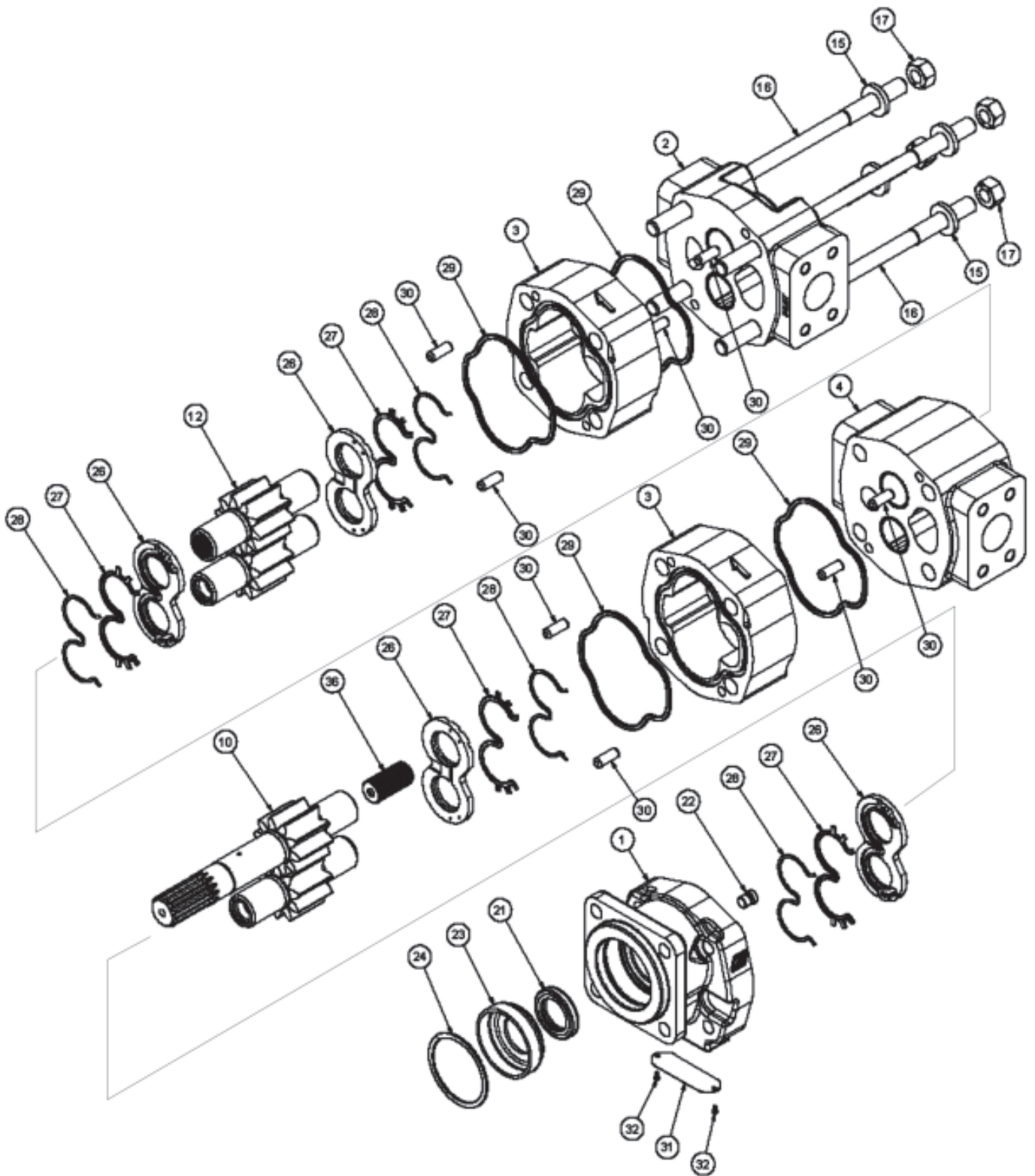

PUMP - SERVICE PARTS (06504002)

ITEM	P/N	QTY.	DESCRIPTION
1	22766	1	HOUSING,SEC
2	06504068	1	HOUSING,PEC
3	02965092	2	HOUSING,GEAR
4	06504069	1	HOUSING,BEARINGCARRIER
10	06504070	1	SET,GEARSHAFT
12	06504071	1	GEAR,SET
15	02961917	4	WASHER
16	06504072	4	STUD
17	06504073	4	NUT,HEX
21	* 22765 (SEE SEAL KIT)	1	SEAL,LIP
22	6T5121	1	PLUG
23	02979970	1	SPACER
24	02979971	1	RING,SNAP
26	02965611	4	THRPL
27	* 06504074 (SEE SEAL KIT)	4	SEAL,CHAN
28	* 06504075 (SEE SEAL KIT)	4	SEAL,BK-UP
29	* 06504076 (SEE SEAL KIT)	4	SEAL,SQ-R
30	02961924	8	PIN,DOWEL
31	06504077	1	NAMEPLATE
32	06504078	2	SCREW,DRIVE
36	06504079	1	SFT,CONN
	* 22764	1	SEAL KIT

2 SP HUSCO - LOAD SENSE (31320)

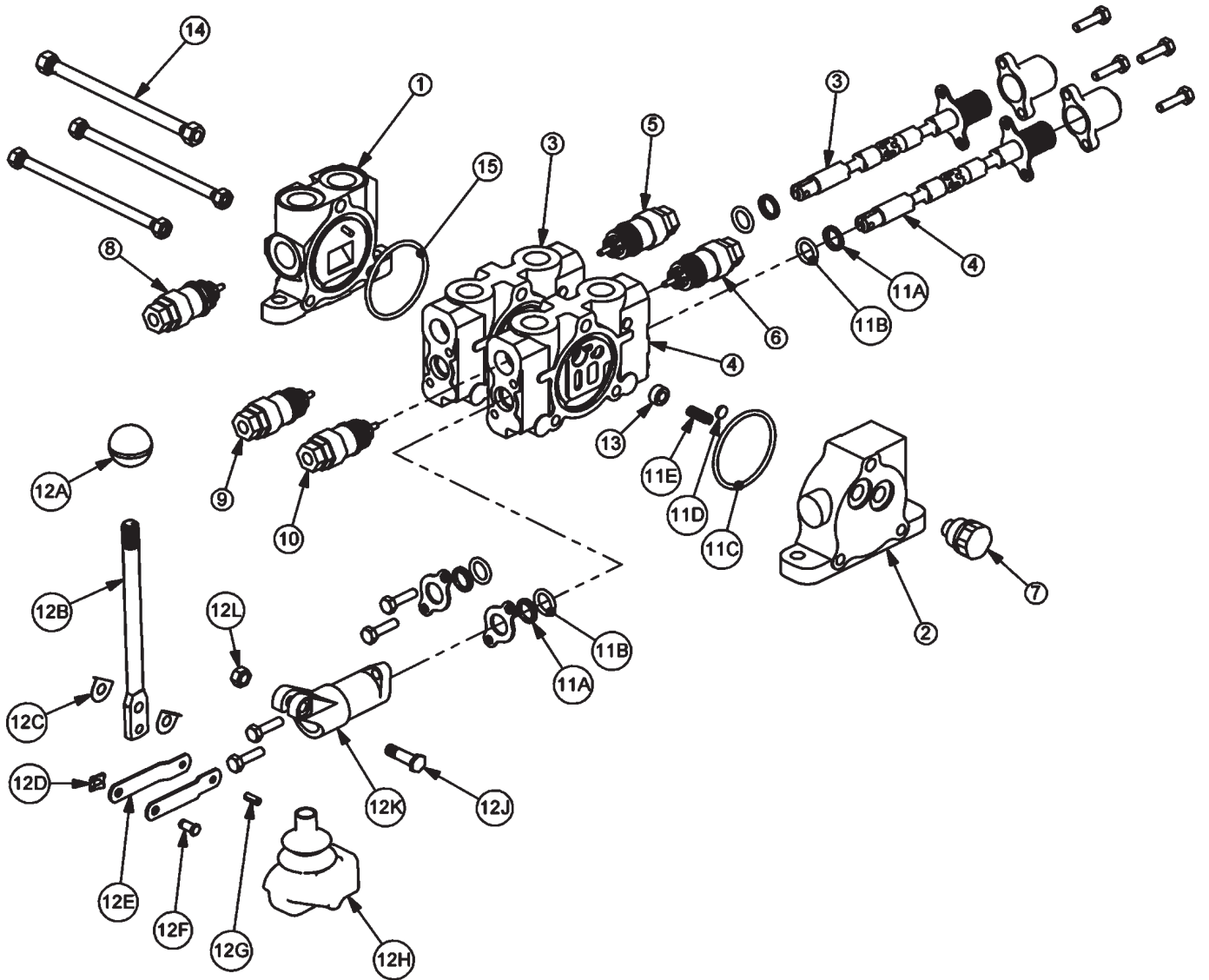

2 SP HUSCO - LOAD SENSE (31320)

ITEM	PART NO.	QTY	DESCRIPTION
1	31595	1	INLET END COVER
2	31594	1	END COVER, LOAD SENSE
3	31597	1	VALVE SECTION (DOUBLE ACTING, CENTER SPRING)
4	31597	1	VALVE SECTION (DOUBLE ACTING, CENTER SPRING)
5	06503067	1	RELIEF PLUG
6	06503067	1	RELIEF PLUG
7	N/A	-	N/A
8	6T4209	1	RELIEF PLUG
9	31862	1	RELIEF VALVE, 2175 PSI
10	31862	1	RELIEF VALVE, 2175 PSI
11	31593	2	VALVE SEAL KIT (FOR ONE SECTION)
11A		2	WIPER
11B		2	O-RING SMALL
11C		1	O-RING LARGE
11D		1	SHUTTLE DISC
11E		1	SPRING
12	TB1017L	2	LEVER KIT (FOR ONE SECTION)
12A		1	LEVER KNOB
12B		1	LEVER
12C		2	LEVER WASHER
12D		1	LEVER CLIP
12E		2	LINKAGE
12F		1	LEVER PIN
12G		1	ROLL PIN
12H		1	LEVER BOOT
12J		1	LEVER BOLT
12K		1	LEVER DUST COVER
12L		1	LEVER NUT
13	31603	2	COMPENSATOR
14	TB1017X	1	TIE ROD KIT
15	24214	1	O-RING, LARGE

2 SP HUSCO - LOAD SENSE (31321)

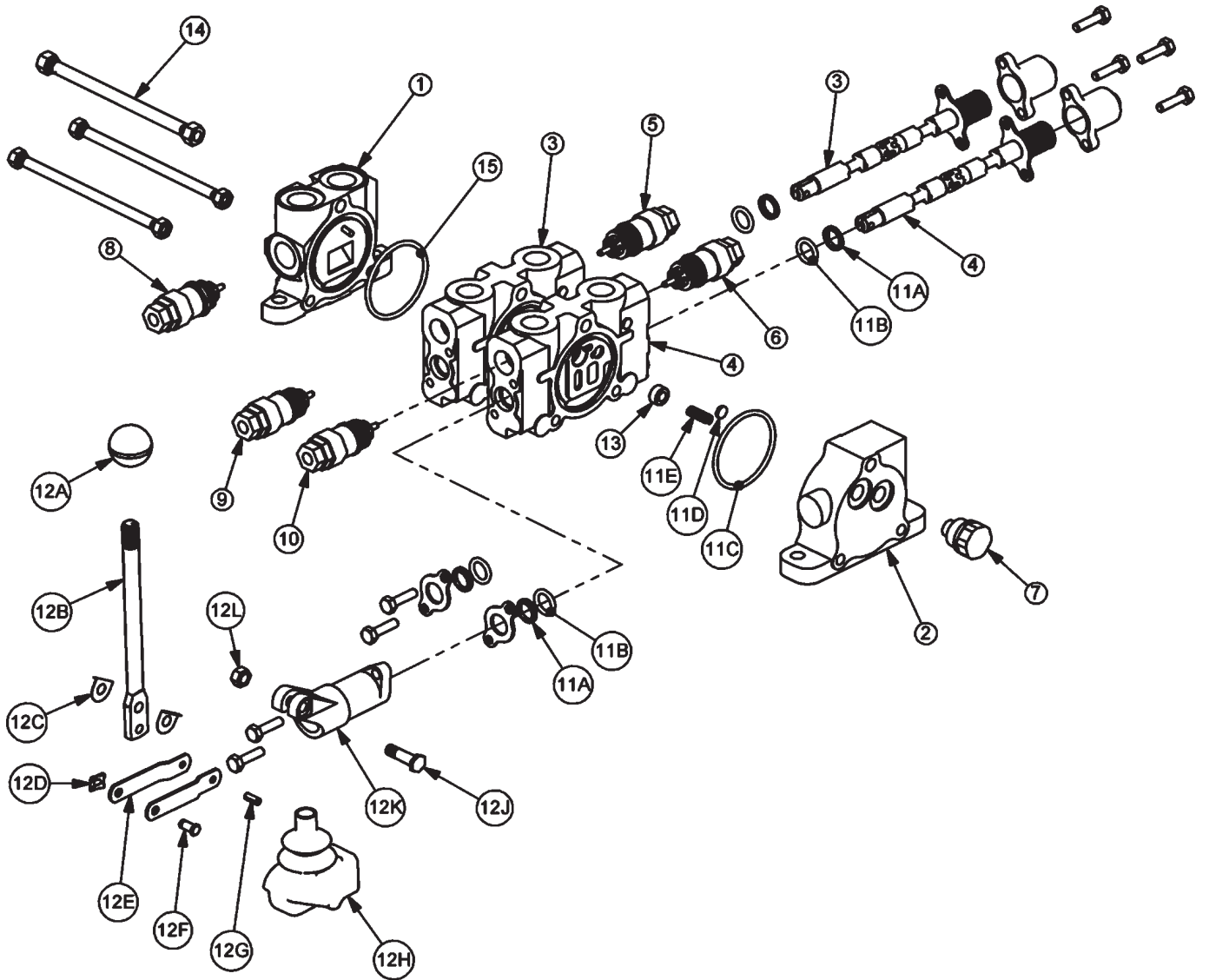

2 SP HUSCO - LOAD SENSE (31321)

ITEM	PART NO.	QTY	DESCRIPTION
1	31595	1	INLET END COVER
2	31594	1	END COVER, LOAD SENSE
3	31597	1	VALVE SECTION (DOUBLE ACTING, CENTER SPRING)
4	31597	1	VALVE SECTION (DOUBLE ACTING, CENTER SPRING)
5	06503067	1	RELIEF PLUG
6	31861	1	RELIEF VALVE, 360 PSI
7	N/A	-	N/A
8	6T4209	1	RELIEF PLUG
9	31862	1	RELIEF VALVE, 2175 PSI
10	31862	1	RELIEF VALVE, 2175 PSI
11	31593	2	VALVE SEAL KIT (FOR ONE SECTION)
11A		2	WIPER
11B		2	O-RING SMALL
11C		1	O-RING LARGE
11D		1	SHUTTLE DISC
11E		1	SPRING
12	TB1017L	2	LEVER KIT (FOR ONE SECTION)
12A		1	LEVER KNOB
12B		1	LEVER
12C		2	LEVER WASHER
12D		1	LEVER CLIP
12E		2	LINKAGE
12F		1	LEVER PIN
12G		1	ROLL PIN
12H		1	LEVER BOOT
12J		1	LEVER BOLT
12K		1	LEVER DUST COVER
12L		1	LEVER NUT
13	31603	2	COMPENSATOR
14	TB1017X	1	TIE ROD KIT
15	24214	1	O-RING, LARGE

3 SP HUSCO - LOAD SENSE CABLE (06502043)

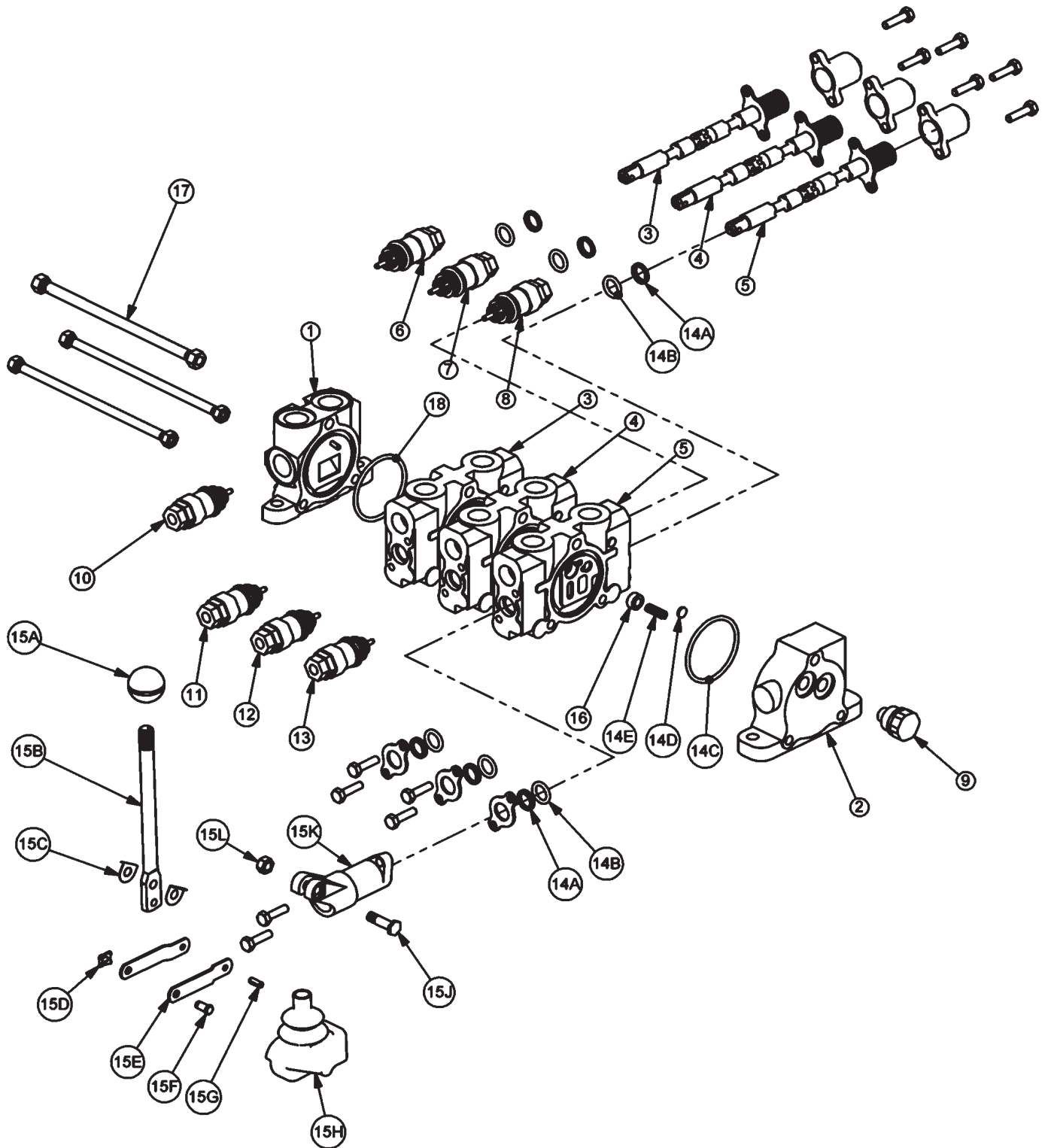

3 SP HUSCO - LOAD SENSE CABLE (06502043)

ITEM	PART NO.	QTY	DESCRIPTION
1	31595	1	INLET END COVER
2	31594	1	END COVER, LOAD SENSE
3	31597	1	VALVE SECTION (DOUBLE ACTING, CENTER SPRING)
4	31597	1	VALVE SECTION (DOUBLE ACTING, CENTER SPRING)
5	31597	1	VALVE SECTION (DOUBLE ACTING, CENTER SPRING) (REMOVE SHUTTLE DISC)
6	06503067	1	RELIEF PLUG
7	06503067	1	RELIEF PLUG
8	28816	1	RELIEF VALVE, 1812 PSI
9	06503068	1	RELIEF PLUG
10	6T4209	1	RELIEF PLUG
11	31862	1	RELIEF VALVE, 2175 PSI
12	31862	1	RELIEF VALVE, 2175 PSI
13	28816	1	RELIEF VALVE, 1812 PSI
14	31593	3	VALVE SEAL KIT (FOR ONE SECTION)
14A		2	WIPER
14B		2	O-RING SMALL
14C		1	O-RING LARGE
14D		1	SHUTTLE DISC
14E		1	SPRING
15	TB1017L	3	LEVER KIT (FOR ONE SECTION)
15A		1	LEVER KNOB
15B		1	LEVER
15C		2	LEVER WASHER
15D		1	LEVER CLIP
15E		2	LINKAGE
15F		1	LEVER PIN
15G		1	ROLL PIN
15H		1	LEVER BOOT
15J		1	LEVER BOLT
15K		1	LEVER DUST COVER
15L		1	LEVER NUT
16	31603	3	COMPENSATOR
17	23397	1	TIE ROD KIT
18	24214	1	O-RING, LARGE

3 SP HUSCO - LOAD SENSE COMBO (06502044)

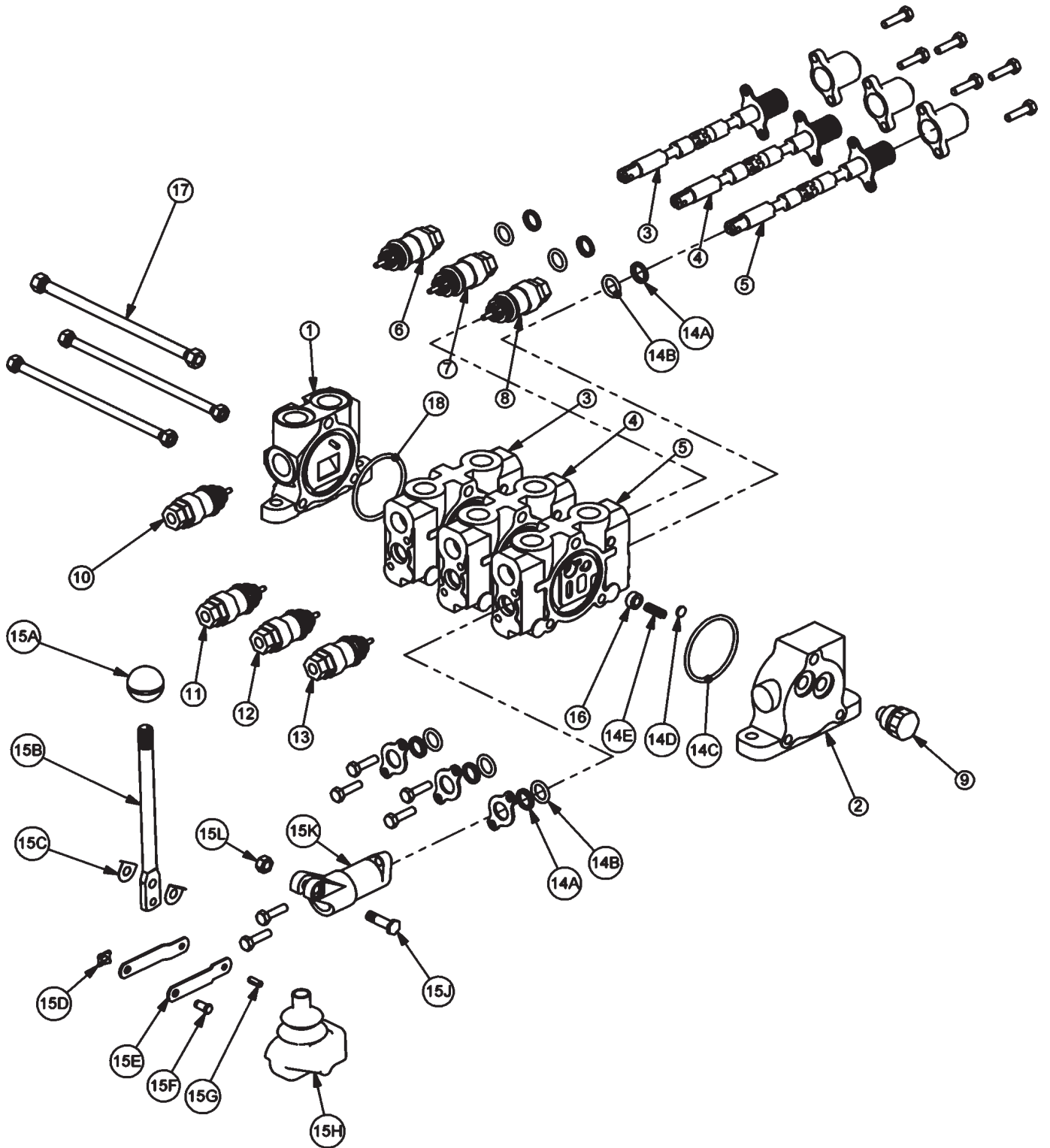

3 SP HUSCO - LOAD SENSE COMBO (06502044)

ITEM	PART NO.	QTY	DESCRIPTION
1	31595	1	INLET END COVER
2	31594	1	END COVER, LOAD SENSE
3	31597	1	VALVE SECTION (DOUBLE ACTING, CENTER SPRING)
4	31597	1	VALVE SECTION (DOUBLE ACTING, CENTER SPRING)
5	31597	1	VALVE SECTION (DOUBLE ACTING, CENTER SPRING) (REMOVE SHUTTLE DISC)
6	06503067	1	RELIEF PLUG
7	31861	1	RELIEF VALVE, 360 PSI
8	28816	1	RELIEF VALVE, 1812 PSI
9	06503068	1	RELIEF PLUG
10	6T4209	1	RELIEF PLUG
11	31862	1	RELIEF VALVE, 2175 PSI
12	31862	1	RELIEF VALVE, 2175 PSI
13	28816	1	RELIEF VALVE, 1812 PSI
14	31593	3	VALVE SEAL KIT (FOR ONE SECTION)
14A		2	WIPER
14B		2	O-RING SMALL
14C		1	O-RING LARGE
14D		1	SHUTTLE DISC
14E		1	SPRING
15	TB1017L	3	LEVER KIT (FOR ONE SECTION)
15A		1	LEVER KNOB
15B		1	LEVER
15C		2	LEVER WASHER
15D		1	LEVER CLIP
15E		2	LINKAGE
15F		1	LEVER PIN
15G		1	ROLL PIN
15H		1	LEVER BOOT
15J		1	LEVER BOLT
15K		1	LEVER DUST COVER
15L		1	LEVER NUT
16	31603	3	COMPENSATOR
17	23397	1	TIE ROD KIT
18	24214	1	O-RING, LARGE

SIDE COOLER

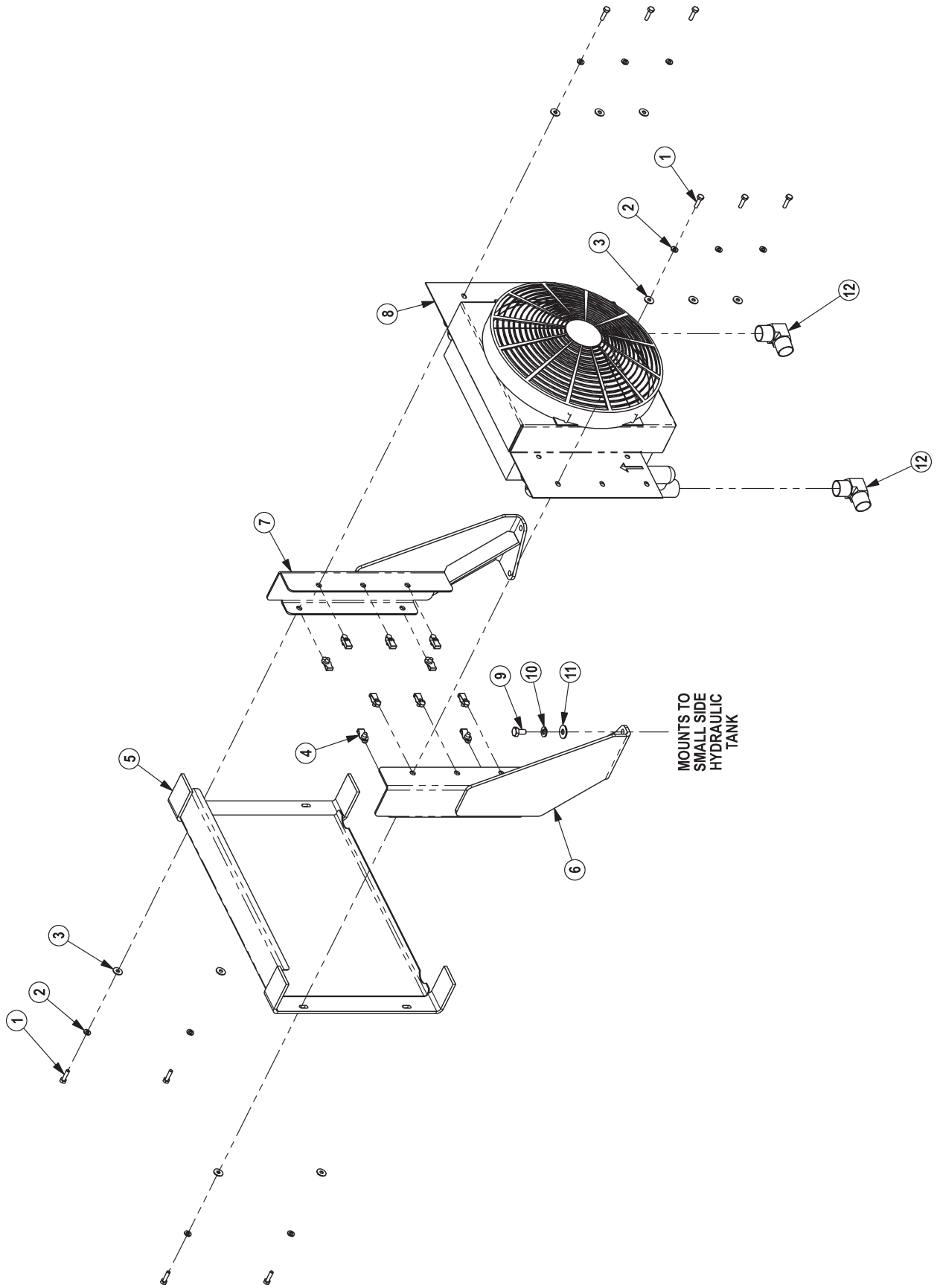

SIDE COOLER

ITEM	PART NO.	QTY.	DESCRIPTION
1	21530	10	CAPSCREW,1/4 X1 NC
2	21986	10	LOCKWASHER,1/4
3	22014	10	FLATWASHER,1/4
4	35176	10	1/4 U-NUT
5	06370015	1	SCREEN,COOLER,FRNT
6	06380006	1	MNT,COOLER,BUMPER TANK,RH
7	06380007	1	MNT,COOLER,BUMPER TANK,LH
8	06510026	1	COOLER,FRONT MNT
9	21629	4	CAPSCREW,3/8 X 3/4 NC
10	21988	4	LOCKWASHER,3/8
11	22016	4	FLATWASHER,3/8
12	34117	2	ELBOW,1MOR X 1MJ90,FORGED

SAFETY STAND

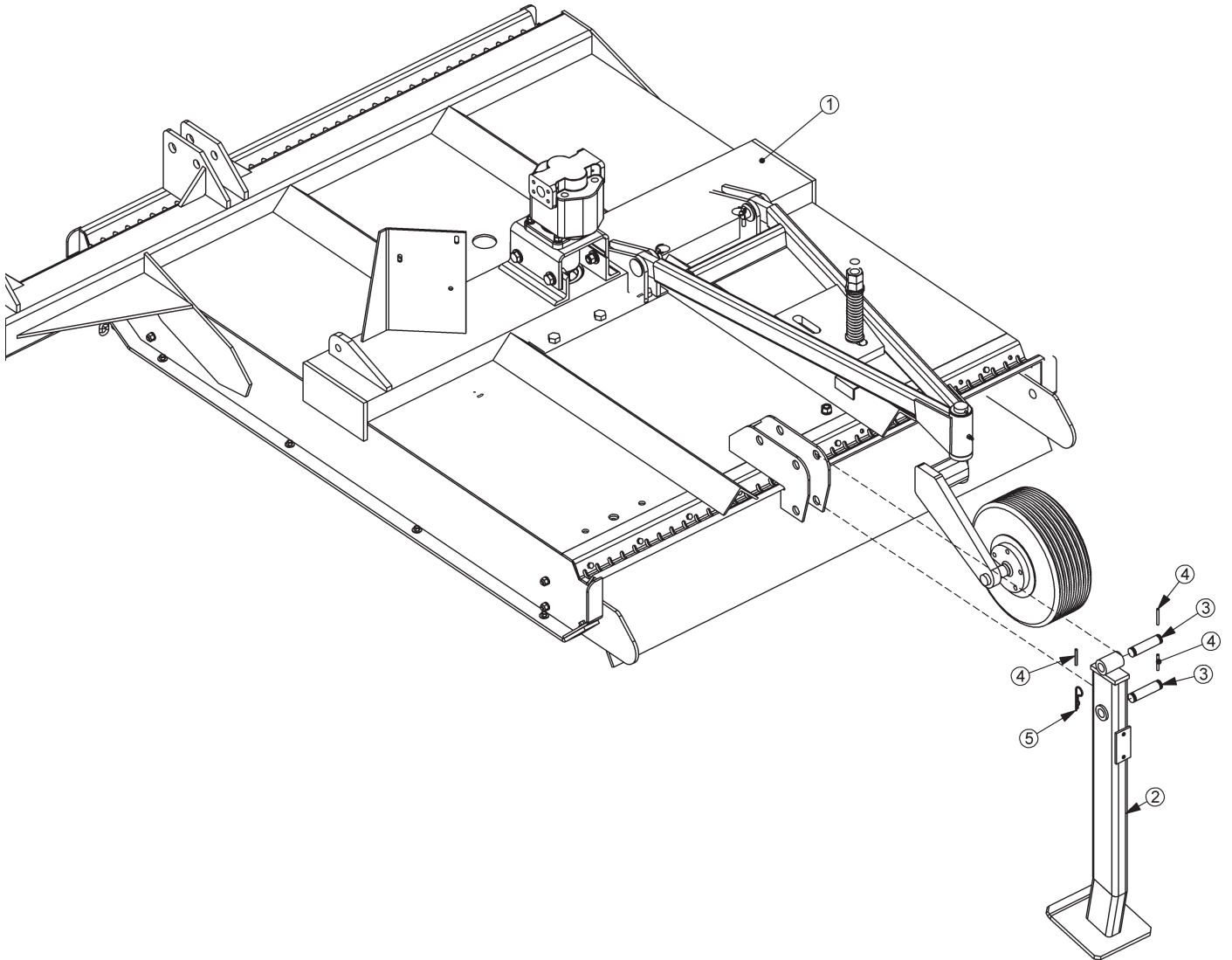

CP23002

ITEM	PART NO.	QTY.	DESCRIPTION
1	REF.	*	REAR RTRY - REFER TO REAR RTRY DECK ASSY
2	28511	1	REAR RTRY STAND
3	TB1033D	2	PIN,CLEVIS 1"X4"(DRILLED7/32)
4	6T3014	3	ROLL PIN, 1/4" x 2"
5	6T3004	1	R-CLIP (HAIRPIN COTTER, 3/16")

CASTER WHEEL ASSEMBLY

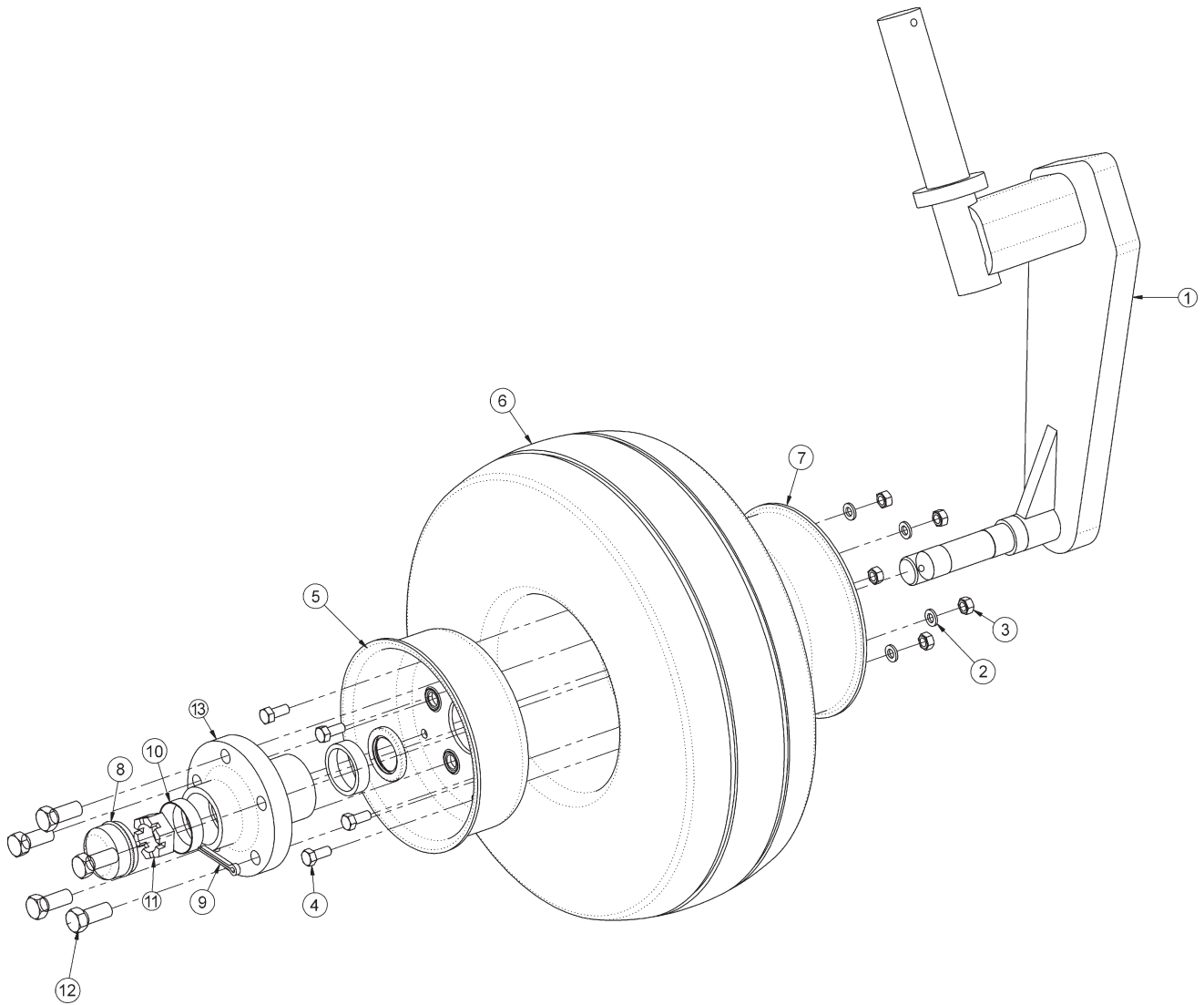

ITEM	PART NO.	QTY.	DESCRIPTION
1	21459	1	SPINDLE, CASTER WHEEL AXLE
2	21987	5	LOCKWASHER, 5/16"
3	21575	5	HEX NUT, 5/16"
4	8548	5	CAPSCREW, 5/16" x 3/4", NC
5	22697-1	1	RIM, OUTER/RR RTRY CASTER ASSY
6	21416	1	TIRE, SOLID, RR-RTRY
7	22696-1	1	RIM, REAR ROTARY CASTER
8	22070	1	DUST CAP
9	22533	1	COTTER PIN, 3/16" X 2"
10	6T0836	2	CUP, CASTER WHEEL
11	22073	1	HEX NUT, 1NF (SLOTTED JAM NUT)
12	22071	5	HUB STUD
13	22066-1	1	HUB CASTER (REAR ROTARY)

BRAKE VALVE ASSEMBLY W/ METRI PAK

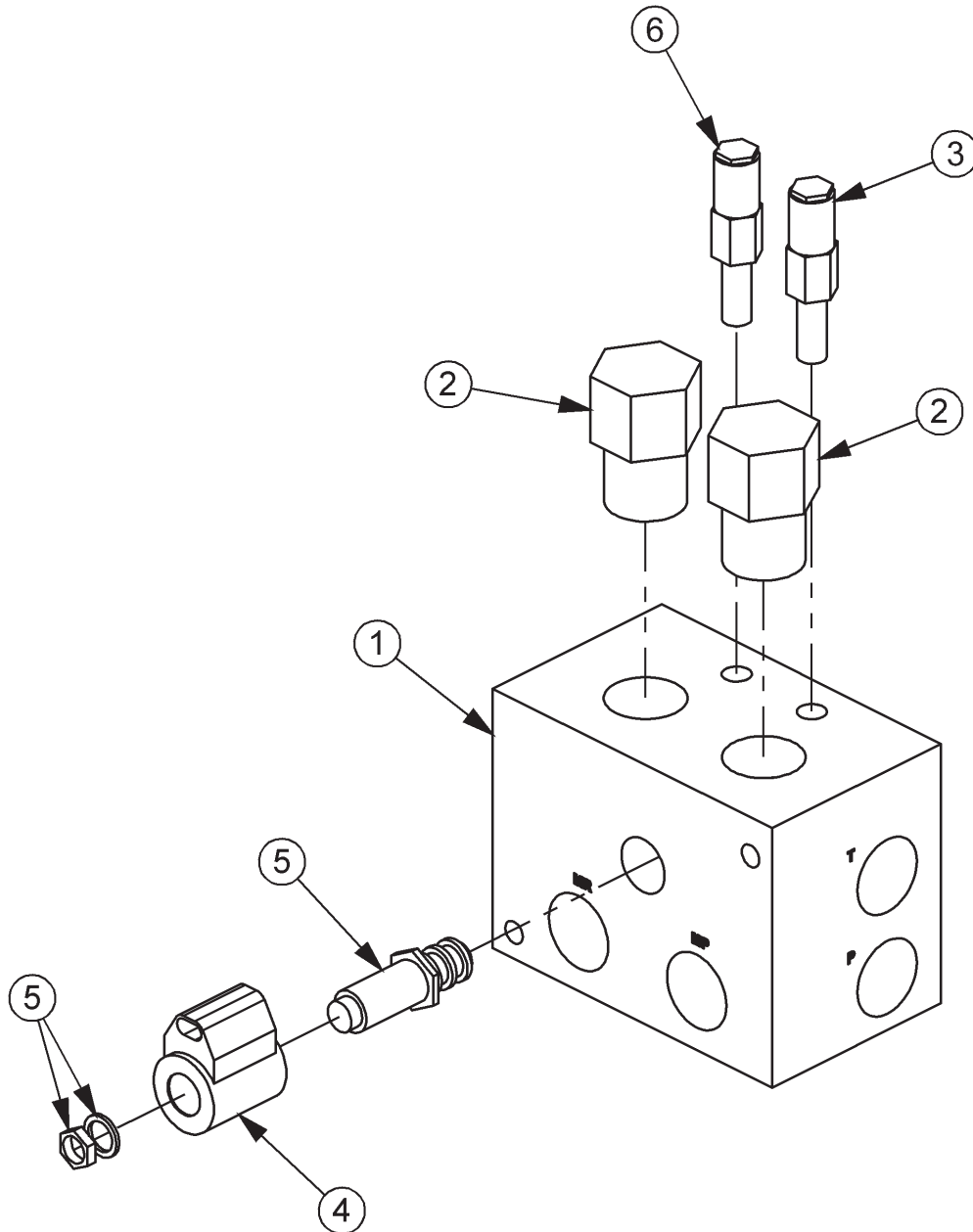

ITEM	PARTNO.	QTY.	DESCRIPTION
1	34092	1	BRAKE VALVE, BLANK
2	34094	2	LOGIC ELEMENT
3	34095	1	RELIEF VALVE, 3500 PSI
4	06510095	1	METRI PAK COIL
5	34093	1	CARTRIDGE, 2 POSITION, 3 WAY (WITH NUT & WASHER)
6	34091	1	RELIEF VALVE, 2600 PSI

SWITCHBOX SERVICE PARTS

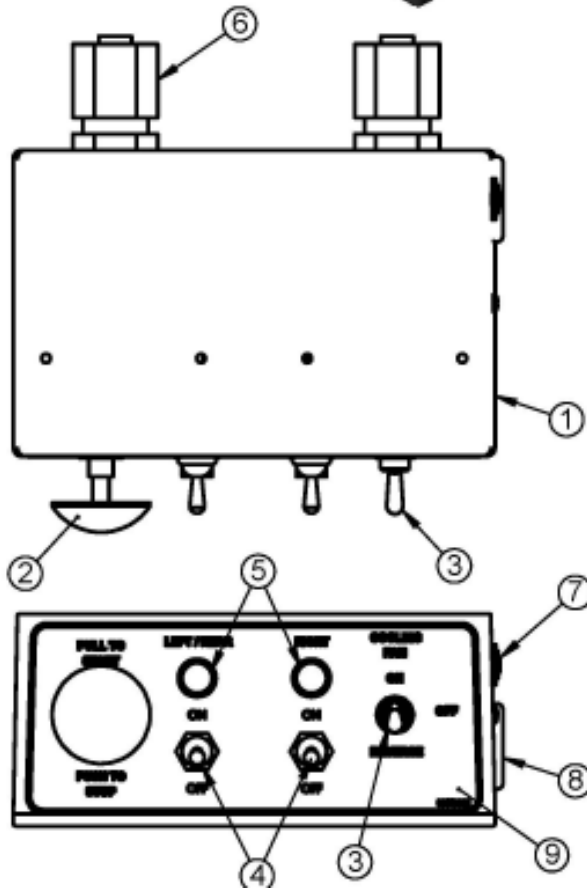

ITEM	P/N	QTY.	DESCRIPTION
1	06514011	1	SWBX,ALUM,BLK,06510097
2	35226	1	SWITCH,MOWER,COLEHERSEE
3	06510028	1	SWITCH,FORWARD/BRAKE/REV
4	33811	2	SWITCH,MASTER/DECK FLOAT
5	6T3923	2	INDICTATOR LIGHT,ON,RED
6	34540	2	STRAIN RELIEF,3/4,BLACK,NYLON
7	06514006	1	BREAKER,15A,SWBX
8	06514015	1	ALARM,SWBX,REVERSER
9	06550002	1	DECAL,SWTCHBX,TWINT/3F,REV FAN
10	35227	1	RELAY,DP,DT,12V,LY2F,35226

SWITCHBOX SCHEMATIC

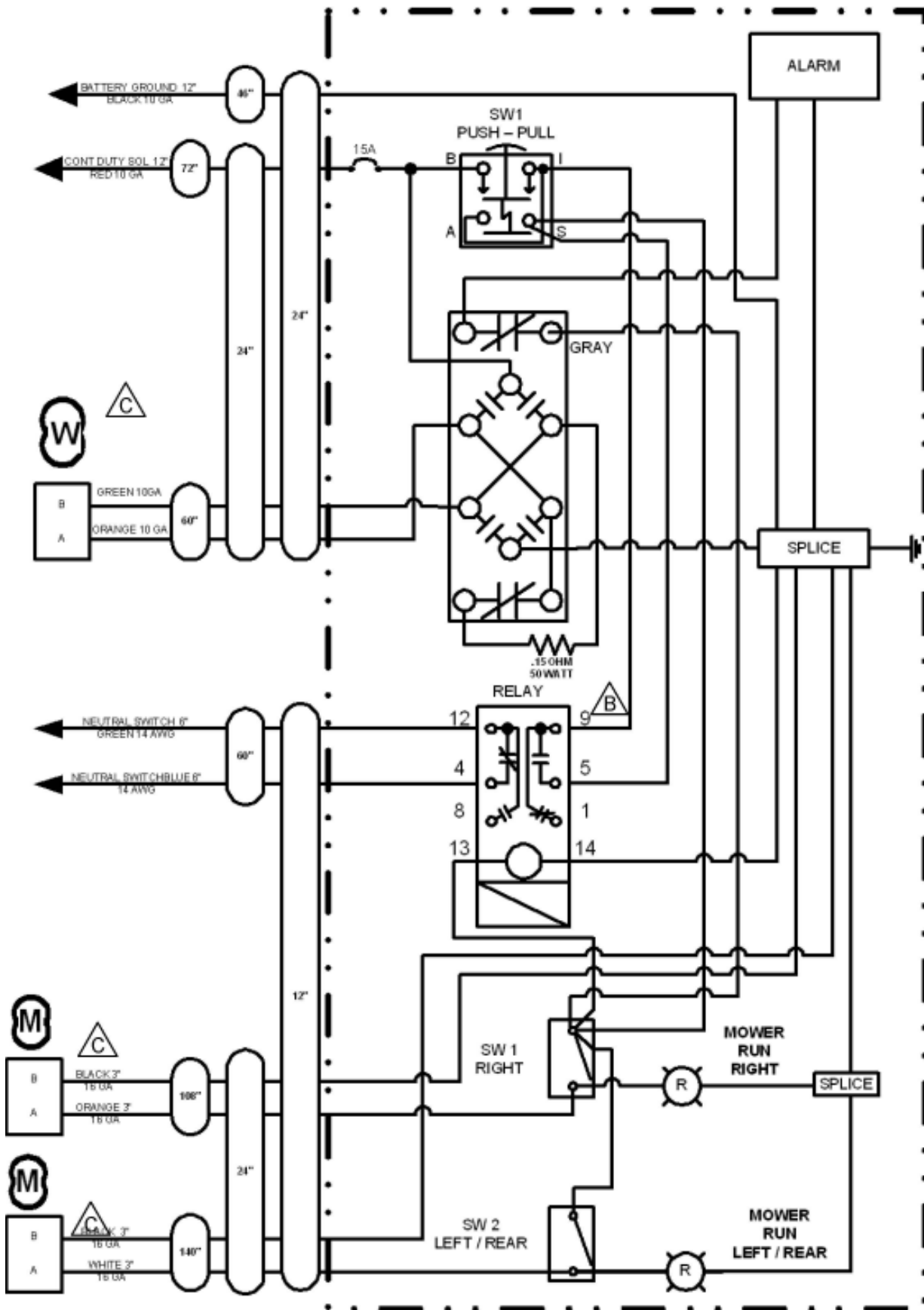

WARRANTY SECTION

WARRANTY INFORMATION

Tiger Corporation, 3301 N. Louise, Sioux Falls, South Dakota, warrants to the original Retail Customer, the new Tiger equipment is free of defects in material and workmanship. Any part of equipment that in Tiger's judgement, show evidence of such defects will be repaired or replaced without charge, provided that the failure of part(s) shall have occurred within twelve (12) months from the date of delivery of said equipment to the Retail Customer. Expendable components such as knives, oil, chain sprockets, skid shoes, knife mounting disks and the like are excluded but not limited to this warranty.

The Retail Customer must pay the transportation cost to and from the Tiger Dealer's service shop for warranty service. Warranty service will be performed by the Tiger Dealer from whom the equipment was purchased, during service shop regularly scheduled days and hours of operation.

All Tiger obligation under this warranty shall be terminated if the equipment is modified or altered in ways not approved in writing by Tiger, if repair parts other than genuine Tiger repair parts have been used, or if the equipment has been subject to misuse, neglect, accident, improper maintenance or improper operation.

Tiger Corporation reserves the right to make improvements in design or changes in specification at any time without incurring any obligation to owners of equipment previously sold.

No agent or person has authority to alter, add to or waive the above warranties which are agreed to be in the only warranties, representations or promises, expressed or implied, as to the quality or performance of the products covered and which do not include any implied warranty of merchantability or fitness. In no event will Tiger be liable for incidental or consequential damages or injuries, including, but not limited to, loss of profits, rental or substitute equipment or other commercial loss.

**THERE ARE NO WARRANTIES WHICH EXTEND
BEYOND THOSE EXPRESSED HEREIN.**

It is the Purchasers obligation to sign the warranty registration form **AFTER** he / she has Read and Understands the Operation and Safety Instructions stated within this manual.

ONE LAST WORD

This manual cannot possibly cover all of the potentially hazardous situations you will encounter. By being familiar with the safety rules, operating and maintenance instructions in this manual you can help prevent accidents. The objective of this manual is to help make you a better operator. Remember, **SAFETY IS YOU!**



1012

Your safety and the safety of those around you depends on **YOU**. Common sense should play a large role in the operation of this machine.

Since we at Tiger Corporation are constantly striving to improve our products, we reserve the right to change specifications or design at any time.

TO THE OWNER / OPERATOR / DEALER



To keep your implement running efficiently and safely, read your manual thoroughly and follow these directions and the Safety Messages in this manual and on the machine. The table of contents clearly identifies each section where you can easily find the information you need.

The Occupational Safety and Health Act (OSHA 1928.51 subpart C) makes the following minimum requirements for tractor operators.

OWNER REQUIREMENTS:

1. Provide a Roll-Over-Protective Structure that meets the requirements of this Standard; and
2. Provide Seatbelts that meet the requirements of this Standard and SAE J3C; and
3. Ensure that each employee uses such Seatbelt while the tractor is moving; and
4. Ensure that each employee tightens the Seatbelt sufficiently to confine the employee to the protected area provided by the ROPS.

OPERATOR REQUIREMENTS:

1. Securely fasten seatbelt if the tractor has a ROPS.
2. Where possible, avoid operating the tractor near steep ditches, embankments, and holes.
3. Reduce speed when turning, crossing slopes, and on rough, slick, or muddy surfaces.
4. Stay off slopes too steep for safe operation.
5. Watch where you are going – especially at row ends, on roads, and around trees.
6. Do Not permit others to ride.
7. Operate the tractor smoothly – no jerky turns, starts, or stops.
8. Hitch only to the draw-bar and hitch points recommended by the tractor manufacturer.
9. When the tractor is stopped, set brakes securely and use park lock, if available



Printed in USA
© Tiger Corporation